

Grp 14C

**BATTERY**



**ORIGINAL BATTERY CABLES**

(Made in the USA from factory blueprints.) Each \$55.00 R

- 14-085A Positive 55-6, 6 cyl.     14-086A Positive 55-6, V8
- 14-086B Negative 55-6, all except cars w/Air
- 14-087B Negative 55-6 w/Factory Air
- 14-088A Positive 57, 6 cyl.     14-088B Negative 57 6 cyl
- 14-089A Positive 57, V8     14-089B Negative 57, V8
- 14-089C Negative 57, original Air Conditioning



**REPLACEMENT BATTERY CABLES USA**

- 14-168 NEGATIVE 57 **17.00 RP**
- 14-169 POSITIVE 57 **19.00 RP**
- 14-170 POSITIVE 55-6 **21.00 RP**
- 14-171 NEGATIVE 55-6 woven ground strap **17.25 RP**
- 14-218 ENGINE GROUND STRAP starter mount to body 55-6 (wide strap) **11.00 RP**

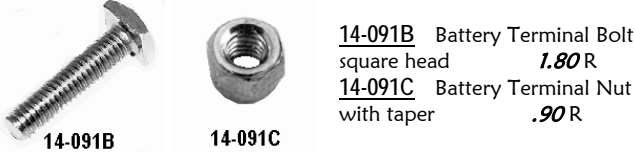

- 14-091B Battery Terminal Bolt square head **1.80 R**
- 14-091C Battery Terminal Nut with taper **.90 R**

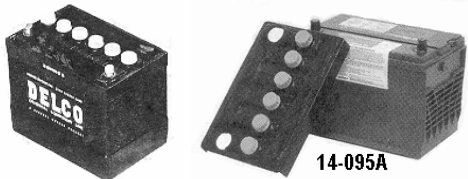

NOTE: We do not sell original Tartop batteries. Try Antique Auto Battery in Hudson OH 330-425-2395, or Axion Battery in New Castle PA 724-654-9300. We do not know if these are available anywhere at this time

14-095A Delco Tartop look BATTERY COVER fits over top of modern Group 24 battery provides appearance of original **Discontinued**

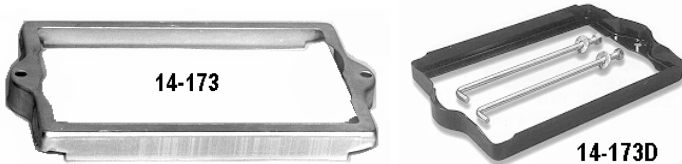

- 14-173 Battery RETAINER 55-56 **13.80 RF**
- 14-173A Battery RETAINER 55-56 **20.00 R**
- 14-173AB Battery RETAINER 55-56 w/bolts **25.00 R**
- 14-173D Battery RETAINER 55-56 w/bolts [Danchuk] **24.00 R**
- 14-173DC Battery RETAINER 55-56 w/bolts, Chrome [Danchuk] **86.00 C**

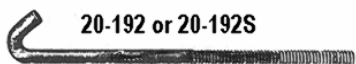

- 20-192 Battery Retainer BOLT w/nut, 55-6 Ea. (2 required) **3.00 R**
- 20-192S Battery BOLT SET Stainless 55-6, 2 bolts, nuts & washers **9.00 R**

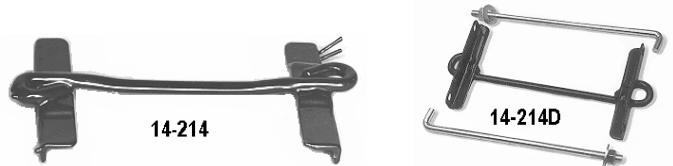

- 14-214 Battery RETAINER, 57 **10.80 R**
- 14-214C Chrome Battery RETAINER 57 w/chrome bolts [Danchuk] fits Around outside of battery **129.95 C**
- 14-214D Battery RETAINER 57 w/bolts [Danchuk] **29.00 R**

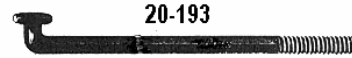

- 20-193 Battery Retainer BOLT, w/hex nut, 57 (2 required) Ea. **4.50 R**
- 20-194 Battery Bolt WINGNUT, 57, Ea. **.50 R**
- 20-194SS Battery Bolt WINGNUT, 57, Ea. Stainless steel **1.50 C**

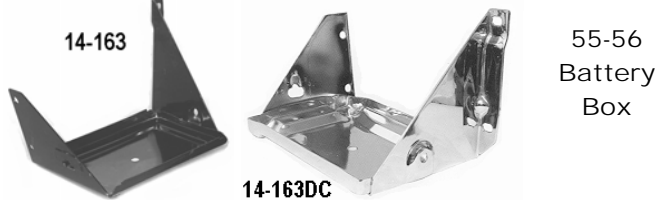

- 14-163 Battery BOX, 55-56 exc Orig. A/C Good Quality **29.95 R**
- 14-163D Battery BOX, 55-56 exc Orig. A/C Danchuk **33.95 R**
- 14-163DC Battery BOX, 55-56 exc Orig. A/C Chrome Dan. **149.00 C**

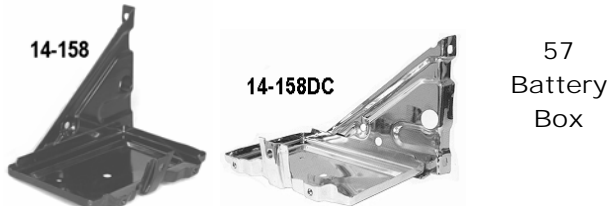

- 14-158 Battery BOX, 57 Good Quality **29.95 R**
- 14-158D Battery BOX, 57 Danchuk version **39.95 R**
- 14-158DC Battery BOX, 57 Chrome, Danchuk **145.00 C**



- WA9323 Battery TRAY & RETAINER 7.5" x 13.25", trunk mount Stainless **44.00 C**
- 14-175 OPTIMA Battery Tray Aluminum **N/A**

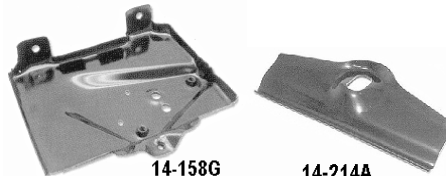

- 14-158G 67-69 Camaro Battery Tray, to make your own trunk mount etc. **17.00**

- 14-214A 66-74 Battery Holddown CLAMP **4.00 R**

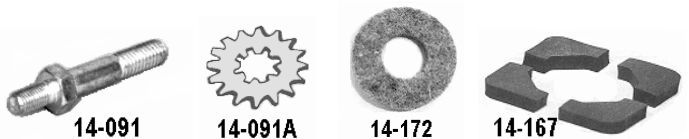

- 14-091 Battery GROUND STUD, 57 V8 all, **Discontinued**
- 14-091A GROUND WASHER, battery & engine ground cables, ea. **.80 R**
- 14-172 Battery TERMINAL FELT WASHERS, pr. **2.50 R**
- 14-167 Battery HOLDOWN PADS, 55-6, set of 4 **9.00 R**



Battery Disconnect Switches

14-092 \$49.00  
 14-092A With Remote Push button \$119.00



FR1061CE

FR1061CE Battery Cable Ends 'No Crimp' Pr

17.50

**Putting Your Battery in the Trunk?**

Use 14-158G & 14-214A and either trunk Mount Battery Cable Kits [30-500723 or 724 with a late model Group 24 Battery that has a vent tube built in. 14-158G can be bolted directly to trunk floor in location of your choice, then drill an additional hole for vent tube from battery.



**Trunk mount Battery Cable Kits**

The Positive (Red) and Negative (Black) cables are each 18' long and are 1 Gauge wire, the lead die cast terminals have molded in steel ring inserts to protect against cracking or breaking the terminals. Each style has its protective boot covers color coded. You also receive the proper end lugs and crimping tool to make connections correctly. Instruction included

30-500723 Battery Cable Kit for Trunk top post 171.00  
 30-500724 Battery Cable Kit for Trunk side post 144.00

**Group 21A**

**WIRE HARNESS**

All harnesses are exact original (except alternator conversion or custom) with correct color code, wrappings and ends, they are made from hi-temperature wire with proper machine done terminations and have passed strict quality control. **There is a difference.** Taillamp harnesses include rubber boots just like original. Top quality Made in USA by

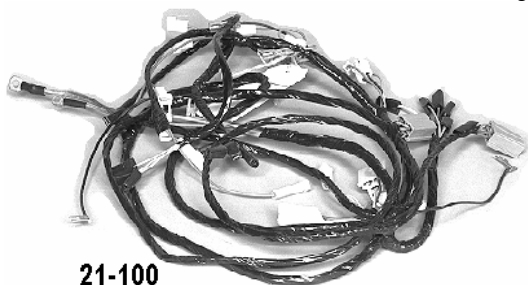

21-100



21-418



21-019

**INDIVIDUAL HARNESSES**

**Factory Fit@Stock Underdash Harness**

21-100 55 includes generator & headlight wiring up to plugs at radiator support as original 272.00 R  
 21-118 56 includes all plastic connectors 265.00 R  
 21-129A 57 includes all plastic connectors 265.00 R

**55 Underdash Harness Wired for Alternator**

Complete replacement for original harness, no cutting or splicing, working 'GEN' light, set up for alternator mounted on Left side

21-418 55 w/Internal Regulator 286.00 C

**Dakota Digital Classic Instruments Custom Gauge UNDERDASH Harness**

To replace underdash harness and mate to digital dash or custom gauges. Simplify installation if you are replacing your underdash harness anyway. All you would need to do is add the terminal ends to wires in this harness to connect to gauges. Includes disconnect for that part of harness

21-DDH55 / 55 \$387. 21-DDH56 / 56 \$387. 21-DDH57 / 57 \$371.

**Headlamp & Generator Harness Stock**

21-117 56 stock 140.00 R  
 21-130 57 V8 stock 140.00 R  
 21-130A 57 6 cyl. stock 147.00 R

**56&57 Headlamp & Alternator Harness**

Plug-In Conversion. Complete replacement for stock generator harness w/all necessary plug ins, working 'GEN' light, with detailed instructions

21-019 56 Internal regulator 166.00 C  
 21-409 57 Internal regulator V8 166.00 C  
 21-409A 57 Internal regulator 6 Cyl. 186.00 C

**Alternator Conversion**

To convert existing harness in car from generator to alternator

21-116 55-6 w/Internal Regulator 74.00 C  
 21-142 57 w/Internal Regulator 80.00 C



21-001

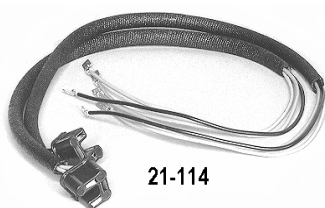

21-114

21-001 Headlamp Harness, 57 w/original plugs & grommets, Pr 53.00 R

21-114 Headlamp Harness, 55-6 with cloth cover, Pr. 53.00 R



**21-115**



**21-144**

21-115 Park Lamp Harness, 55-6 w/rubber covers as original, sockets snap into housing Pr. **48.00 R**

21-115B Park Lamp Harness, 55-6 plugs for original type socket pressed in housings Pr **34.75 R**

21-144 Grill Bar Harness, 57 w/original boots **53.00 R**



**21-132**



**21-150A**



**21-113**

**55 Ignition & Starter**

<u>21-101</u>	55 V8, stick shift	<b>94.00 R</b>
<u>21-102</u>	55 V8, automatic	<b>101.00 R</b>
<u>21-103</u>	55 6 cyl., stick shift	<b>101.00 R</b>
<u>21-104</u>	55 6 cyl., automatic	<b>118.00 R</b>
<u>21-410</u>	55 V8 automatic w/Air Cond.	<b>101.00 R</b>
<u>21-411</u>	55 V8 stick shift w/Air Cond.	<b>106.00 R</b>
<u>21-050</u>	55 V8 stick shift w/ H.E.I. or other electronic distributor	<b>101.00 C</b>
<u>21-051</u>	55 V8 automatic w/H.E.I. or other electronic distributor	<b>113.00 C</b>

21-500204 HEI Hot Wire Connector to Cap w/terminal end **5.00 C**

**56 Ignition & Starter**

<u>21-119</u>	56 V8 automatic	<b>101.00 R</b>
<u>21-120</u>	56 V8 stick	<b>101.00 R</b>
<u>21-121</u>	56 6 cyl. automatic	<b>120.00 R</b>
<u>21-122</u>	56 6 cyl. stick shift	<b>101.00 R</b>
<u>21-280</u>	56 V8 automatic w/Air Cond.	<b>125.00 R</b>
<u>21-281</u>	56 V8 stick shift w/Air Cond.	<b>125.00 R</b>
<u>21-052</u>	56 V8 stick shift w/H.E.I. or other electronic distributor	<b>113.00 C</b>
<u>21-053</u>	56 V8 automatic w/H.E.I. or other electronic distributor	<b>113.00 C</b>

21-500205 HEI Tach Wire Connector to Cap w/terminal end **5.00 C**

**57 Ignition & Starter**

<u>21-131</u>	57 V8 stick shift	<b>101.00 R</b>
<u>21-132</u>	57 V8 automatic	<b>101.00 R</b>
<u>21-133</u>	57 6 cyl. stick shift	<b>101.00 R</b>
<u>21-134</u>	57 6 cyl. automatic	<b>113.00 R</b>
<u>21-282</u>	57 V8 automatic w/2 4 barrels	<b>120.00 R</b>
<u>21-283</u>	57 V8 stick shift w/2 4 barrels	<b>120.00 R</b>
<u>21-284</u>	57 V8 automatic fuel injection	<b>125.00 R</b>
<u>21-436</u>	57 V8 stick w/fuel injection	<b>113.00 R</b>
<u>21-054</u>	57 V8 stick shift w/H.E.I. or other electronic distributor	<b>106.00 C</b>
<u>21-055</u>	57 V8 automatic w/H.E.I. or other electronic distributor	<b>101.00 C</b>

**55 TAILLAMP Harnesses**

<u>21-110</u>	55 2 Dr Hardtop B/A	<b>199.00 R</b>
<u>21-111</u>	55 2 Dr Sdn, & HT 210	<b>199.00 R</b>
<u>21-150A</u>	55 Convertible	<b>272.00 R</b>
<u>21-112</u>	55 Nomad	<b>259.00 R</b>
<u>21-152A</u>	55 2 & 4 Dr Wgn 210	<b>226.00 R</b>
<u>21-112A</u>	55 2 & 4 Dr Wgn 150	<b>239.00 R</b>
<u>21-112B</u>	55 4 Dr. Wgn B/A	<b>249.00 R</b>
<u>21-147A</u>	55 4 Dr Sedan	<b>212.00 R</b>

**56 TAILLAMP Harnesses**

<u>21-111A</u>	56 2D Sdn, 2D HT	<b>193.00 R</b>
<u>21-150B</u>	56 Convertible	<b>265.00 R</b>
<u>21-128</u>	56 Nomad	<b>249.00 R</b>
<u>21-128A</u>	56 2Dr. Wagon 150	<b>239.00 R</b>
<u>21-152B</u>	56 2 & 4 Dr. Wgn	<b>239.00 R</b>
<u>21-147B</u>	56 4 Dr. Sedan	<b>239.00 R</b>
<u>21-402</u>	56 4 Dr. Hardtop	<b>212.00 R</b>

**Note: Call for models not shown**

**57 TAILLAMP Harnesses**

<u>21-140</u>	57 2 Dr. Hardtop	<b>193.00 R</b>
<u>21-141</u>	57 Convertible	<b>252.00 R</b>
<u>21-145</u>	57 Nomad	<b>252.00 R</b>
<u>21-140A</u>	57 2 Dr. Sedan	<b>193.00 R</b>
<u>21-146</u>	57 4 Dr. Sedan	<b>212.00 R</b>
<u>21-151C</u>	57 4 Dr. Wagon	<b>236.00 R</b>
<u>21-145A</u>	57 2 Dr. Wgn 150	<b>226.00 R</b>
<u>21-152C</u>	57 2 Dr. Wgn 210	<b>226.00 R</b>
<u>21-403</u>	57 4 Dr. Hardtop	<b>239.00 R</b>

**BACK-UP LAMP Harness**

57 Backup Lamp Assemblies, see Grp 17

<u>21-113</u>	55-56	<b>52.00 R</b>	<u>21-138</u>	57	<b>40.00 R</b>
---------------	-------	----------------	---------------	----	----------------



**21-149**



**21-021**

**GLOVE BOX DOOR LIGHT ASSEMBLY**

<u>21-149</u>	55	<b>27.00 R</b>	<u>21-149A</u>	56-7	<b>27.00 R</b>
---------------	----	----------------	----------------	------	----------------

**HEATER FAN**

<u>21-107</u>	MOTOR LEAD WIRE, 55	<b>13.00 R</b>
<u>21-107A</u>	MOTOR POWER WIRE, 55	<b>13.00 R</b>
<u>21-107B</u>	LAMP WIRE, Heater and AC Control, 55	<b>13.00 R</b>
<u>21-035</u>	MOTOR LEAD WIRE, 57 resistor to motor connector	<b>130.00 R</b>

**CLOCK HARNESS**

<u>21-106</u>	55	<b>27.00 R</b>	<u>21-124</u>	56	<b>27.00 R</b>	<u>21-136</u>	57	<b>27.00 R</b>
---------------	----	----------------	---------------	----	----------------	---------------	----	----------------

**MISCELLANEOUS**

<u>21-105</u>	FUSE PANEL HARNESS, 55	<b>26.00 R</b>
<u>21-434</u>	LICENSE LIGHT Harness, one for each light Ea.	<b>18.00</b>
<u>21-030</u>	Fuel TANK LEAD WIRE, 56-7, 7 1/2" long	<b>13.00 R</b>
<u>21-021</u>	TRUNK / UNDERHOOD LIGHT KIT comes with bracket bulb and internal switch	<b>35.00 C</b>
<u>21-004</u>	Accessory COMPASS LIGHT Harness	<b>N/A</b>
<u>21-031</u>	A/C COMPRESSOR LEAD, 55 relay to compressor	<b>15.00 R</b>
<u>21-032</u>	A/C CONTROL LEAD, 55 relay to therm. switch	<b>20.00 R</b>
<u>21-033</u>	A/C CONTROL LEAD, 55 relay to fuse panel	<b>15.00 R</b>
<u>21-034</u>	AC LEAD WIRE, 55 fuse panel to blower switch	<b>13.00 R</b>
<u>21-036</u>	AC CONTROL WIRE, 57 AC compressor lead	<b>11.00 R</b>
<u>21-037</u>	AC CONTROL WIRE, 57 resistor to evap. switch	<b>11.00 R</b>

**POWER WINDOW**

**Harness**

Each R

<u>21-041A</u>	55 2 dr HT	<b>399.</b>
<u>21-041B</u>	55 2 dr Sedan	<b>399.</b>
<u>21-041C</u>	55 Convertible	<b>414.</b>
<u>21-041E</u>	55 4 dr All	<b>399.</b>
<u>21-042A</u>	56 2 dr HT	<b>399.</b>
<u>21-042B</u>	56 2 dr Sdn	<b>399.</b>
<u>21-042C</u>	56 Convertible	<b>414.</b>
<u>21-042E</u>	56 4 dr All	<b>399.</b>
<u>21-042F</u>	56 4 dr HT	<b>399.</b>
<u>21-043A</u>	57 2 dr HT	<b>399.</b>
<u>21-043B</u>	57 2 dr Sedan	<b>399.</b>
<u>21-043C</u>	57 Convertible	<b>414.</b>
<u>21-043E</u>	57 4 dr All	<b>399.</b>
<u>21-043F</u>	57 4 dr HT	<b>399.</b>

<u>21-041D</u>	55 Nomad	<b>265.00</b>
<u>21-042D</u>	56 Nomad	<b>265.00</b>
<u>21-043D</u>	57 Nomad	<b>265.00</b>

21-041G ADAPTER HARNESS,  
55-6 harness to 57 & up  
motors, ea. **22.00**

**UNDERDASH COURTESY**

*LAMP HARNESS*

<u>21-334</u>	55-56 Set	<b>52.00 R</b>
<u>21-335</u>	57 Set	<b>52.00 R</b>

**Convertible POWER TOP**

**LEAD Wire**

Starter solenoid to  
power top connector

also original accessory feed

<u>21-026</u>	55-6 6 cyl.	<b>18.00</b>
<u>21-027</u>	55-6 V8	<b>18.00</b>
<u>21-028</u>	57 6 cyl.	<b>20.00</b>
<u>21-029</u>	57 V8	<b>18.00</b>

**OVERDRIVE**

**Wire Harness**

Each R

<u>21-016</u>	55 6 cyl.	<b>137.</b>
<u>21-108</u>	55 V8	<b>132.</b>
<u>21-017</u>	56 6 cyl.	<b>132.</b>
<u>21-123</u>	56 V8	<b>132.</b>
<u>21-018</u>	57 6 cyl.	<b>132.</b>
<u>21-135</u>	57 V8	<b>137.</b>
<u>21-135A</u>	57 V8 w/2- 4's	<b>137.</b>

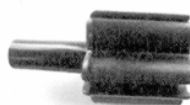

**21-333A**

21-333A Overdrive Connector  
plastic 4 wire for Kickdown  
switch, **20.00 R**



**21-333**

21-333 Overdrive CABLE  
under dash w/chrome "T" handle  
replacement, no mark on handle,  
6' long **N/A**

**Power Seat Harness**

<u>21-34220</u>	Control, 55-6	<b>39.00</b>
<u>21-31715</u>	Control, 57	<b>39.00</b>
<u>21-32890</u>	Feed, 55-6	<b>39.00</b>
<u>21-31710</u>	Feed, 57	<b>39.00</b>



**21-467B**

Late Model Steering  
Column Turn Signal  
Conversion Harness

Adapts late model wiring to  
original harness, plugs in.  
no splicing, includes horn wire  
& makes 4 way flashers  
functional. Others available.

**Each \$50.00**

<u>21-467A</u>	55 to 69-74 Column
<u>21-467B</u>	55 to 75-up Column

<u>21-468A</u>	56 to 69-74 Column
<u>21-468B</u>	56 to 75-up Column

<u>21-469A</u>	57 to 69-74 Column
<u>21-469B</u>	57 to 75-up Column

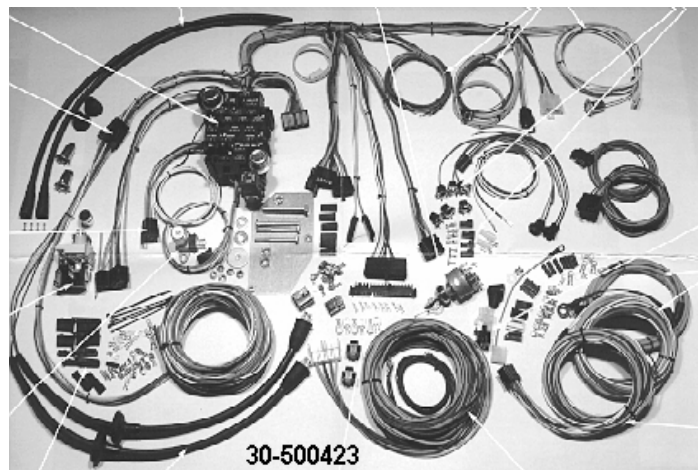

**30-500423**

**CLASSIC UPDATE SERIES Wire Harness Kit**

(from American Autowire)

A complete full function system for easy access, installation and connectivity with common update accessories while allowing for future expansion. Designed around the specs & dimensions of 55-7 as well as the space constraints imposed by many aftermarket accessories vying for the limited space under the dash. These kits are not generic street rod kits marketed to 55-7 owners. Superior design has given the builder complete flexibility to use stock switches and components as well as update accessories such as Dakota Digital Instruments, Raingear Wiper Systems, Vintage Air Heat & Ac units, IDIDIT and Flaming River Steering Columns, & late model GM Tilt columns. The fuse box was chosen for adaptability in mounting & its ability to handle increased current loads for power accessories such as windows, locks, seats, cruise control etc. It is a GM design that has heavy-duty circuit bussing,

(no circuit board as power demands would be too high for a circuit board). This attention to detail removes the engineering exercise from the builder & makes installation much smoother. **Includes** Fuse Box with 18 fused circuits & expansion possibility for 11 additional power circuits. Fuse Link protection on fuse panel power feed, Circuit breaker capability. High Heat resistant wire. GM color code. Wire description ink jet printed every 3 inches. Plug-in installation of most circuits. Turn Signal Flasher, 4Way Flasher & Horn Relay mounted on fuse panel. 8 Gage Alternator lead with fuse link protection & connector for 'SI' series & 1-wire alternators. Original boot & tube & light sockets. Terminals & connectors for dome lamp & jamb switches for 2 & 4 door. Front lighting includes original connectors & boots with extra long wire leads for custom routing. Complete wiring for GM steering column with mating connectors to adapt to original column. Ignition switch connectors provided for columns with switch in them. Engine wiring for points & HEI distributor, power & tach connectors supplied for HEI. Gauge sender leads for water temp, fuel, oil pressure, voltmeter & tach. Power wiring for electric fan, fuel pump, power windows, power door locks, cruise, radio, power seats. Instrument cluster disconnect built in, all original terminals, connectors, light sockets are supplied for original cluster wiring. Cluster disconnect also supports any custom gauge configuration (Autometer, VDO, Classic etc.). Late model GM Head Light Switch included. Detailed installation instruction & wire schematics.

<u>30-500423</u>	CLASSIC UPDATE SERIES KIT, 55-6	<b>749.00 C</b>
<u>30-500434</u>	CLASSIC UPDATE SERIES KIT, 57	<b>749.00 C</b>

30-500444 Convertible TOP POWER HARNESS, if using Classic Update harness kit 30-500423 or 434 on a convertible you will need this. **39.90 C**

## Factory Fit® HARNESS SETS

Includes all major harnesses; Headlight, Parklight, Underdash, Generator or Alternator, Taillight, Ignition & Starter. Instructions & diagrams supplied.

HEI listing for any electronic distributor. Alternator listings are Internal regulator. Alternator wired kits are for driver side mounted alternator.

These reproductions are fully assembled, taped with all terminals attached & original wire color code.

55 2 dr HT			56 2 dr HT			57 2 dr HT		
<u>21-K100</u>	V8 Auto Generator	<b>671.00</b>	<u>21-K116</u>	V8 Auto Generator	<b>795.00</b>	<u>21-K132</u>	V8 Auto Generator	<b>798.00</b>
<u>21-K101</u>	V8 Stick Generator	<b>663.00</b>	<u>21-K117</u>	V8 Stick Generator	<b>795.00</b>	<u>21-K133</u>	V8 Stick Generator	<b>798.00</b>
<u>21-K102</u>	V8 Auto Alternator	<b>685.00</b>	<u>21-K118</u>	V8 Auto Alternator	<b>822.00</b>	<u>21-K134</u>	V8 Auto Alternator	<b>825.00</b>
<u>21-K103</u>	V8 Stick Alternator	<b>678.00</b>	<u>21-K119</u>	V8 Stick Alternator	<b>822.00</b>	<u>21-K135</u>	V8 Stick Alternator	<b>825.00</b>
<u>21-K102A</u>	V8 Auto Alternator, HEI	<b>697.00</b>	<u>21-K118A</u>	V8 Auto Alternator, HEI	<b>834.00</b>	<u>21-K134A</u>	V8 Auto Alternator, HEI	<b>825.00</b>
<u>21-K103A</u>	V8 Stick Alternator, HEI	<b>685.00</b>	<u>21-K119A</u>	V8 Stick Alternator, HEI	<b>834.00</b>	<u>21-K135A</u>	V8 Stick Alternator, HEI	<b>830.00</b>
55 Convertible			56 Convertible			57 Convertible		
<u>21-K104</u>	V8 Auto Generator	<b>743.00</b>	<u>21-K120</u>	V8 Auto Generator	<b>868.00</b>	<u>21-K136</u>	V8 Auto Generator	<b>859.00</b>
<u>21-K105</u>	V8 Stick Generator	<b>736.00</b>	<u>21-K121</u>	V8 Stick Generator	<b>868.00</b>	<u>21-K137</u>	V8 Stick Generator	<b>859.00</b>
<u>21-K106</u>	V8 Auto Alternator	<b>756.00</b>	<u>21-K122</u>	V8 Auto Alternator	<b>894.00</b>	<u>21-K138</u>	V8 Auto Alternator	<b>885.00</b>
<u>21-K107</u>	V8 Stick Alternator	<b>750.00</b>	<u>21-K123</u>	V8 Stick Alternator	<b>894.00</b>	<u>21-K139</u>	V8 Stick Alternator	<b>885.00</b>
<u>21-K106A</u>	V8 Auto Alternator, HEI	<b>769.00</b>	<u>21-K122A</u>	V8 Auto Alternator, HEI	<b>907.00</b>	<u>21-K138A</u>	V8 Auto Alternator, HEI	<b>885.00</b>
<u>21-K107A</u>	V8 Stick Alternator, HEI	<b>757.00</b>	<u>21-K123A</u>	V8 Stick Alternator, HEI	<b>907.00</b>	<u>21-K139A</u>	V8 Stick Alternator, HEI	<b>889.00</b>
55 2 dr Sedan			56 2 dr Sedan			57 2 dr Sedan		
<u>21-K108</u>	V8 Auto Generator	<b>671.00</b>	<u>21-K124</u>	V8 Auto Generator	<b>795.00</b>	<u>21-K140</u>	V8 Auto Generator	<b>798.00</b>
<u>21-K109</u>	V8 Stick Generator	<b>663.00</b>	<u>21-K125</u>	V8 Stick Generator	<b>795.00</b>	<u>21-K141</u>	V8 Stick Generator	<b>798.00</b>
<u>21-K110</u>	V8 Auto Alternator	<b>685.00</b>	<u>21-K126</u>	V8 Auto Alternator	<b>822.00</b>	<u>21-K142</u>	V8 Auto Alternator	<b>825.00</b>
<u>21-K111</u>	V8 Stick Alternator	<b>677.00</b>	<u>21-K127</u>	V8 Stick Alternator	<b>822.00</b>	<u>21-K143</u>	V8 Stick Alternator	<b>825.00</b>
<u>21-K110A</u>	V8 Auto Alternator, HEI	<b>697.00</b>	<u>21-K126A</u>	V8 Auto Alternator, HEI	<b>834.00</b>	<u>21-K142A</u>	V8 Auto Alternator, HEI	<b>825.00</b>
<u>21-K111A</u>	V8 Stick Alternator, HEI	<b>685.00</b>	<u>21-K127A</u>	V8 Stick Alternator, HEI	<b>834.00</b>	<u>21-K143A</u>	V8 Stick Alternator, HEI	<b>830.00</b>
55 Nomad			56 Nomad			57 Nomad		
<u>21-K112</u>	V8 Auto Generator	<b>730.00</b>	<u>21-K128</u>	V8 Auto Generator	<b>841.00</b>	<u>21-K144</u>	V8 Auto Generator	<b>859.00</b>
<u>21-K113</u>	V8 Stick Generator	<b>723.00</b>	<u>21-K129</u>	V8 Stick Generator	<b>841.00</b>	<u>21-K145</u>	V8 Stick Generator	<b>859.00</b>
<u>21-K114</u>	V8 Auto Alternator	<b>744.00</b>	<u>21-K130</u>	V8 Auto Alternator	<b>868.00</b>	<u>21-K146</u>	V8 Auto Alternator	<b>885.00</b>
<u>21-K115</u>	V8 Stick Alternator	<b>737.00</b>	<u>21-K131</u>	V8 Stick Alternator	<b>868.00</b>	<u>21-K147</u>	V8 Stick Alternator	<b>885.00</b>
<u>21-K114A</u>	V8 Auto Alternator, HEI	<b>757.00</b>	<u>21-K130A</u>	V8 Auto Alternator, HEI	<b>880.00</b>	<u>21-K146A</u>	V8 Auto Alternator, HEI	<b>885.00</b>
<u>21-K115A</u>	V8 Stick Alternator, HEI	<b>744.00</b>	<u>21-K131A</u>	V8 Stick Alternator, HEI	<b>880.00</b>	<u>21-K147A</u>	V8 Stick Alternator, HEI	<b>889.00</b>
55 4 dr Sedan			56 4 dr Sedan			57 4 dr Sedan		
<u>21-K150</u>	V8 Auto Generator	<b>684.00</b>	<u>21-K162</u>	V8 Auto Generator	<b>841.00</b>	<u>21-K174</u>	V8 Auto Generator	<b>820.00</b>
<u>21-K151</u>	V8 Stick Generator	<b>675.00</b>	<u>21-K163</u>	V8 Stick Generator	<b>841.00</b>	<u>21-K175</u>	V8 Stick Generator	<b>820.00</b>
<u>21-K152</u>	V8 Auto Alternator	<b>697.00</b>	<u>21-K164</u>	V8 Auto Alternator	<b>868.00</b>	<u>21-K176</u>	V8 Auto Alternator	<b>850.00</b>
<u>21-K153</u>	V8 Stick Alternator	<b>690.00</b>	<u>21-K165</u>	V8 Stick Alternator	<b>868.00</b>	<u>21-K177</u>	V8 Stick Alternator	<b>850.00</b>
<u>21-K152A</u>	V8 Auto Alternator, HEI	<b>709.00</b>	<u>21-K164A</u>	V8 Auto Alternator, HEI	<b>880.00</b>	<u>21-K176A</u>	V8 Auto Alternator, HEI	<b>850.00</b>
<u>21-K153A</u>	V8 Stick Alternator, HEI	<b>697.00</b>	<u>21-K165A</u>	V8 Stick Alternator, HEI	<b>880.00</b>	<u>21-K177A</u>	V8 Stick Alternator, HEI	<b>852.00</b>
55 2 & 4d Wagon			56 2 & 4d Wagon			57 2d Wagon		
<u>21-K154</u>	V8 Auto Generator	<b>697.00</b>	<u>21-K166</u>	V8 Auto Generator	<b>841.00</b>	<u>21-K178</u>	V8 Auto Generator	<b>834.00</b>
<u>21-K155</u>	V8 Stick Generator	<b>690.00</b>	<u>21-K167</u>	V8 Stick Generator	<b>841.00</b>	<u>21-K179</u>	V8 Stick Generator	<b>834.00</b>
<u>21-K156</u>	V8 Auto Alternator	<b>712.00</b>	<u>21-K168</u>	V8 Auto Alternator	<b>868.00</b>	<u>21-K180</u>	V8 Auto Alternator	<b>860.00</b>
<u>21-K157</u>	V8 Stick Alternator	<b>703.00</b>	<u>21-K169</u>	V8 Stick Alternator	<b>868.00</b>	<u>21-K181</u>	V8 Stick Alternator	<b>860.00</b>
<u>21-K156A</u>	V8 Auto Alternator, HEI	<b>723.00</b>	<u>21-K168A</u>	V8 Auto Alternator, HEI	<b>880.00</b>	<u>21-K180A</u>	V8 Auto Alternator, HEI	<b>860.00</b>
<u>21-K157A</u>	V8 Stick Alternator, HEI	<b>710.00</b>	<u>21-K169A</u>	V8 Stick Alternator, HEI	<b>880.00</b>	<u>21-K181A</u>	V8 Stick Alternator, HEI	<b>866.00</b>
56 4 dr HT			57 4 dr HT			57 4d Wagon		
<u>21-K186</u>	V8 Auto Generator	<b>815.00</b>	<u>21-K190</u>	V8 Auto Generator	<b>850.00</b>	<u>21-K182</u>	V8 Auto Generator	<b>834.00</b>
<u>21-K187</u>	V8 Stick Generator	<b>815.00</b>	<u>21-K191</u>	V8 Stick Generator	<b>850.00</b>	<u>21-K183</u>	V8 Stick Generator	<b>834.00</b>
<u>21-K188</u>	V8 Auto Alternator	<b>841.00</b>	<u>21-K192</u>	V8 Auto Alternator	<b>866.00</b>	<u>21-K184</u>	V8 Auto Alternator	<b>861.00</b>
<u>21-K189</u>	V8 Stick Alternator	<b>841.00</b>	<u>21-K193</u>	V8 Stick Alternator	<b>866.00</b>	<u>21-K185</u>	V8 Stick Alternator	<b>861.00</b>
<u>21-K188A</u>	V8 Auto Alternator, HEI	<b>854.00</b>	<u>21-K192A</u>	V8 Auto Alternator, HEI	<b>866.00</b>	<u>21-K184A</u>	V8 Auto Alternator, HEI	<b>861.00</b>
<u>21-K189A</u>	V8 Stick Alternator, HEI	<b>854.00</b>	<u>21-K193A</u>	V8 Stick Alternator, HEI	<b>868.00</b>	<u>21-K185A</u>	V8 Stick Alternator, HEI	<b>866.00</b>

For variations on listed items Call, Fax or email

## Sockets / Pigtails / Terminals / Fuses

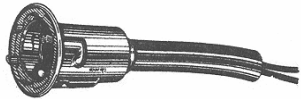

21-225

**21-225** Park or Taillight SOCKET double contact w/boot & 7" pigtail snap-in type. Ea. **6.95 RP**

**21-434** License Lamp SOCKET, original type. Ea. **11.00 R**

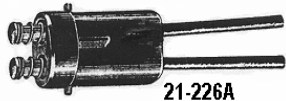

21-226A

**21-226A** PLUG-IN WIRE PIGTAIL for Park or Taillight original pressed-in sockets, 6" pigtail Ea. **12.00 R**



21-113A

**21-113A** Back Up Lamp SOCKET KIT 55-6 [no wires] **17.50 R**

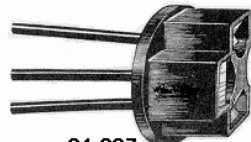

21-227

**21-227** Headlight Bulb WIRE PLUG, 3 wire 12" pigtails **4.50 RP**



21-339



21-339A

### Dash Lamp Sockets

**21-339** SOCKET, w/6" pigtail, replacement. Ea. **4.00 RP**

**21-339A** SOCKET SET, 55 includes 6 metal and 2 plastic bulb sockets for dash gauge cluster as original **35.00 R**

**21-038** 56 auto trans column shift INDICATOR LIGHT **11.00 R**

**21-039** 57 heater control PANEL LIGHT **11.00 R**

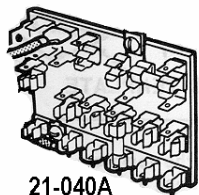

21-040A

**21-040A** FUSE PANEL, 55-6, 57 replacement Ea. **53.00 R**

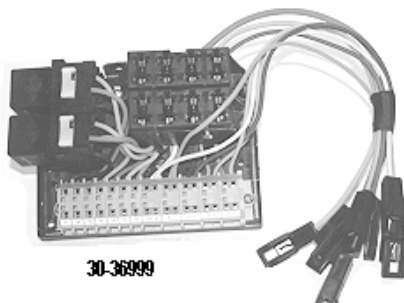

30-36999

### Replacement ATO Fuse Panels:

Plug-in 8 circuit replacement for the old glass fuse original equipment panel.

These mount in the original locations and attach to the original dash harness without modification. This system provides 4 fused battery circuits, 4 fused ignition circuits, a battery fused 4 way hazard flasher circuit and a power relay circuit in the most compact package on the market. Additional connections are provided for up to 6 fused ignition accessories and 7 fused battery accessories including instrument lighting. This is a high quality panel with high temperature wire, patented wire lock technology, using common available components [relay etc.]. Detailed instructions included.

**30-36999** ATO Replacement Fuse Panel, 55 **139.00**

**30-37000** ATO Replacement Fuse Panel, 56-7 **139.00**

**30-37001** FUSE PACK for ATO Fuse Panels above includes fuses required plus spares 22 pc [4 /7.5, 3 /10, 3 /15, 8 /20 2 /25, 2 /30 amp **15.00**

**21-PRF70402** Weatherpack Connector 2 wire disassembled, no wire included. To combine 2 devices to go in the same sender Ea. **10.00 C**



21-458

### GLASS FUSES

**21-455** SET, 55, 6 pc. includes all exc. AC & OD fuse **10.00 R**

**21-456** SET, 56, 6 pc. includes all exc. AC & OD fuse **10.00 R**

**21-457** SET, 57, 6 pc. includes all exc. AC & OD fuse **10.00 R**

**21-458** AGC-15, Ea. **1.50 R**      **21-459** SFE-9, Ea. **2.50 R**

**21-460** SFE-7 1/2, Ea. **1.50 R**      **21-461** AGA-3, Ea. **1.50 R**



12079  
11618

**12079** Glass FUSE HOLDER, in line 18g wire pigtails 1-1/4 long, up to 20 amp **2.50**

**11618** Glass FUSE HOLDER, in line 12g wire pigtails with 30 amp fuse included **3.00**

**12592** Glass FUSE PULLER **6.00**

**13445** FUSE BLOCK 4 gang for sfe-20 glass fuses, Each **12.00 C**



12592



13445



21-475A

### WIRE DISCONNECTS

uses OEM male/female terminals

**21-475** 4 wire connections **6.00 RP**

**21-475A** 3 wire connections **6.00 RP**

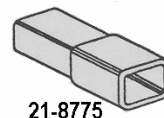

21-8775



21-8777



21-8776



21-8774

### Wire Terminals OEM for original plastic harness connectors

**21-8776** Male for 14-16 gauge wire, Ea. brass **.65 R**

**21-15956** Male for 14-16 gauge wire, Ea. tin plated **.65 R**

**21-17002** Male for 10-12 gauge wire, Ea. **.65 R**

**21-8775** Male Insulator, plastic for 21-8776/17002, Ea. **.65 R**

**21-8774** Female for 14-16 gauge wire, Ea. brass **.65 R**

**21-15957** Female for 14-16 gauge wire, Ea. tin plated **.65 R**

**21-8777** Female Insulator, plastic for 21-8774/15957, Ea. **.65 R**

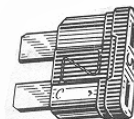

ATO Fuses

### ATO/ATC Fuses \$.95 Ea

**12537** 7.5 Amp      **12538** 10 Amp

**12539** 15 Amp      **12540** 20 Amp

**12541** 25 Amp      **12542** 30 Amp



12363

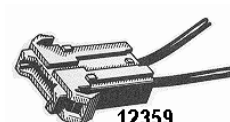

12359



17-009M1

**17-009M1** ATO HD FUSE HOLDER 30 amp 12g 4" wire leads Ea **3.00**

**12359** ATO FUSE HOLDER 20 amp 14g 4" wire leads Ea. **3.50**

**12363** ATO FUSE HOLDER 20 amp 16g 4" wire leads Ea **3.00**

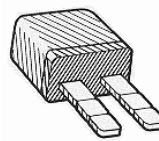

17-009M2



15046

**17-009M2** CIRCUIT BREAKER 30 amp auto re-set, break-off legs to fit fuse holder 17-009M1 **8.75**

**15046** CIRCUIT BREAKER 30 amp auto re-set fits SHORT LEGS will fit 17-009M1 if 1/4" cut off the top of it **12.00**



18450

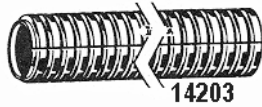

14203

**CUSTOM WIRING AIDS**

**Locking Ring Terminals** [great for frame or body grounds] Each  
**18451** 5/16 Ring 14-16 g **.80**      **18450** 3/8 Ring 10-12 g **N/A**

Wire Loom Black Split Flexible Tubing sold by the foot

<b>14201</b> ¼ id 3/8 od <b>.45</b>	<b>14202</b> 3/8 id 9/16 od <b>.55</b>
<b>14203</b> 1/2 id 11/16 od <b>.60</b>	<b>14204</b> 3/4 id 15/16 od <b>.90</b>
<b>20536</b> 5/8 id 13/16 od <b>.80</b>	<b>18194</b> 1" id 1-1/8 od <b>.85</b>

**Woven CLOTH WIRE LOOM black** sold by the foot  
 [call for other sizes up to 7/8 ID available]

<b>21-DEL701</b> 3/16 ID, good for one wire, water temp sender etc <b>1.40</b>
<b>21-DEL702</b> 1/4 ID, sold by the foot <b>1.45</b>
<b>21-DEL704</b> 3/8 ID, sold by the foot, <b>1.95</b>
<b>21-DEL706</b> 1/2 ID, sold by the foot, <b>2.10</b>

**Heat Shrink Tubing** Black Shrinks by half sold in 6" lengths

<b>18696</b> 1/8 <b>.38</b>	<b>18697</b> 3/16 <b>.42</b>
<b>18698</b> 1/4 <b>.50</b>	<b>18699</b> 3/8 <b>.62</b>
<b>18700</b> 1/2 <b>.70</b>	<b>18701</b> 3/4 <b>1.06</b>
<b>18702</b> 1" <b>1.56</b>	<b>18703</b> 1-1/2 <b>3.08</b>
<b>18704</b> 2" <b>N/A</b>	



30-500548

Male/Female Disconnect w/Grommet  
**30-500548** 57 grill bar pass thru set  
 4 wire 1-1/4 hole **21.00**  
**30-500564** 6 wire harness  
 disconnect 1-3/8 hole **18.00**

**30-500547** 8 wire harness disconnect w/grommet 1-1/2 hole **17.00**  
**30-500566** 9 wire harness disconnect w/grommet 1-3/4 hole **26.00**

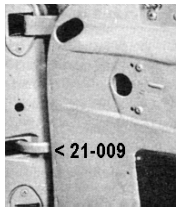

< 21-009



21-009

**21-009** Wire Harness DOOR JAMB TUBES, the original way power window wires were routed to body from doors. Easiest way to route any wires even on modified applications as most cars were made with center punch holes (to drill the required holes) in them already, Pr. **47.00 R**

**Taillight Tube / Grommet Assembly**

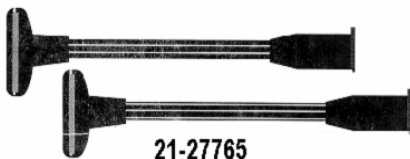

21-27765



21-500186

<b>23-149A</b> 56 Taillight all exc. wagon, Pr. <b>N/A</b>
<b>21-27765</b> 55 Taillight all exc. wagon, Pr. <b>29.90 R</b>
<b>21-27766</b> 57 Taillights exc. wagon, Pr. <b>29.90 R</b>
<b>21-500186</b> GROMMET Taillight wires in trunk wall, Ea. <b>4.70 R</b>

**Grp 21B Switches, Sending Units**

Upper Steering Column Parts See Steering Column Group 17C



21-20015

**Turn Signal Switch**  
 Each **24.00 R**

**21-20015** 55 w/correct terminals  
**21-20016** 56 w/correct terminals & connector  
**21-20017** 57 w/ correct terminals & connector

**21-20017K** Turn Signal Harness CONNECTOR, 57 both halves **8.00 R**



21-437

**21-437** Turn Signal FLASHER heavy duty **5.95 R**

**21-005** HAZARD FLASHER ADAPTER KIT for cars not originally equipped Ea. **N/A**

**21-437A** Turn Signal FLASHER for cars with LED signals **10.90 C**

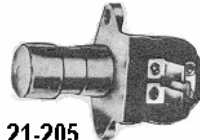

21-205

**21-205** DIMMER SWITCH **23.00 RP**

**BRAKE LIGHT SWITCH**



21-441

**21-441** Metal Housing **22.25 R**



21-207

**21-207** Plastic **6.50 RP**



21-210

**21-212**

**HORN RELAYS**

**21-210** 55-56 **23.00 RP**  
**21-212** 57 **26.00 RP**

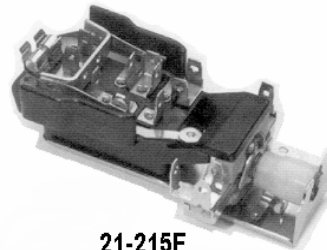

21-215F

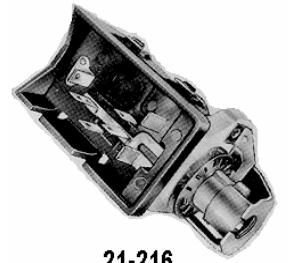

21-216

**HEADLIGHT SWITCH**

Note: High Power Modern Headlights require a relay system.

**21-215F** 55-56 Fargo **39.90 RF**      **21-215FD** 55-56 Danchuk **48.00 RF**  
**21-216** 57 **39.00 R**

**21-215RPK** Replacement Headlight Switch KIT 55-6 for replacement of stock switch with late model switch. Includes color-coded connection harness for easy interface with existing dash harness and accessory block connections. New headlight switch not included. Use with 21-215RP **36.00 RP**

**21-215RP** Replacement Headlight Switch 55-6 Use with 21-215RPK **26.00 RP**



21-215C

**Headlight Switch KNOBS**



21-215N

<b>21-215C</b> 55 Bel Air best <b>17.50 R</b>
<b>21-215C-2</b> 55 Bel Air very good <b>9.00 R</b>
<b>21-215N</b> Headlight Switch NUT, 55-6 holds switch to dash <b>14.75 R</b>



21-215C1

56 Bel Air  
21-215C1 BEST 17.50 R  
21-215C1-2 Very Good 9.00 R



21-216N



21-216C-2



21-913

21-216C 57 Headlight Switch Knob Bel Air BEST 17.50 R  
21-216C-2 57 Headlight Switch Knob Bel Air Very Good 9.00 R  
21-216N Headlight Switch NUT, 57 has 3 extra threads 15.50 R  
21-913 Headlight Switch & Wiper Switch Nut TOOL 19.00



21-217



21-218



21-949

IGNITION SWITCH Lock Cylinders SEE Group 21F page 135

21-217 55-56 (less lock & keys) 85.00 R  
21-217A 55-56 (with lock & keys) 99.00 R  
21-217F 55-56 (less lock & keys) Fargo 49.00 RF  
21-218 57 (less lock & keys) 85.00 R  
21-218A 57 (with lock & keys) 99.00 R  
21-949 Ignition Switch Nut TOOL 20.95



30-510736

Updated Ignition Switch comes w/unique bezel & ring not an original replacement

30-510735 55-6 41.00 C  
30-510736 57 41.00 C



12-001A

Convertible Top Switch KNOB & Shaft  
12-001 55-6 30.00 R  
12-001A 57 35.00

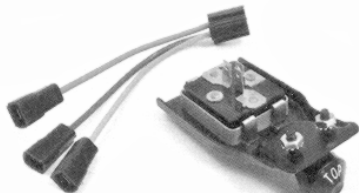

21-165A

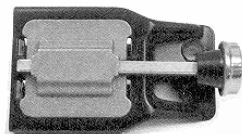

21-165B

21-165A Convertible Top SWITCH Complete w/bracket 55-6 239.00 R  
21-165B Convertible Top SWITCH Complete w/bracket 57 239.00 R

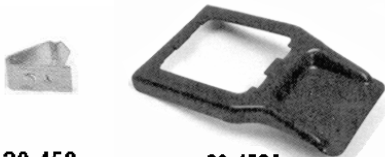

20-458A  
 Convertible TOP SWITCH MOUNT BRACKET 39.00 R

20-458 TOP SWITCH CLIP, holds top switch together, 4 req., Ea. 4.50 R

NEUTRAL SAFETY SWITCH



21-432

21-432 POWERGLIDE original 55-56

21-433 POWERGLIDE original 57



21-433

29.00 R

29.95 R



21-249

21-249 TURBOHYDRAMATIC 350, 400, & overdrive automatics 57 w/original TURBOGLIDE. Column mounted 19.90 C

Extension Harness for trans mounted neutral switches

21-439A 55-6 \$24.00 C

21-439B 57 \$24.00 C

21-432A SCREW Neutral Switch to Column, all .40 R  
21-432B BACK-UP LIGHT SWITCH 55-6 Stick Column. Ea. 29.75 R



21-220

21-220 OIL PRESSURE SENDER, Replacement 15.00 RP  
21-220A OIL PRESSURE SENDER, 55 original pin type NOS 35.00



21-222AC

Water Temperature Senders

21-221A 56 original (for stock 56 electric gauge) correct pin connector and ohm rating 28.00 R

21-222 57-61 Standard 18.50 R  
21-222AC 57-61 AC-Delco N/A

More senders in Group 29 Page 225



21-221W

21-221W Temp Sender WIRE REPAIR KIT 14.50 R

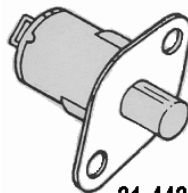

21-442

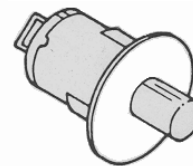

21-443

Dome Lamp SWITCH

21-442 55-6 23.00

21-442D 55-6 Danchuk 25.00

21-443 57 23.00

21-443D 57 Danchuk 25.00



21-214B

21-214B WATERPROOF RELAY KIT, Perfect for under hood applications. Universal 5 contact relay that can be used for electric fan, fuel pump etc. Includes wiring for normally closed circuit making it adaptable as an anti-theft relay. Complete with instructions. 81.00 C  
 see also 17-009G page 79



**GAS TANK SENDING UNITS** Includes gasket & strainer  
For GAUGES See Group 29 Page 217

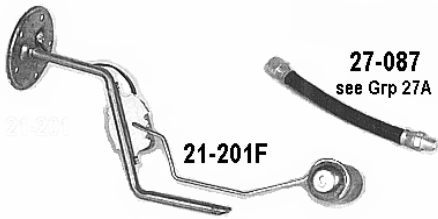

- 21-201F 5/16 line except wagons & FI/2-4's **58.00 RF**  
21-202F Wagon 5/16 line [except 9 PASS] **55.00 RF**  
21-202N Wagon 56-7, 9-passenger **85.00 RF**

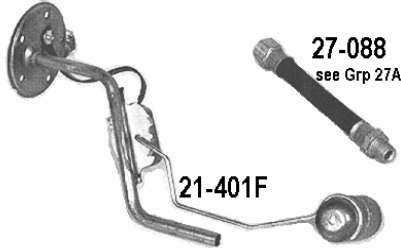

- 21-400 Wagon 3/8 line, FI or 2-4's [except 9 PASS] **55.00 RF**  
21-401F 3/8 line all high performance except wagon **58.00 RF**  
21-201C Gas Tank SENDER FLOAT only, ea. 53-60 brass **8.95 R**  
21-201CP Gas Tank Float replacement in plastic each **6.50 RF**

**Gas Tank Sender Screw Set**

- 20-366 5 Phillips head w/copper washers **4.40 RP**  
21-201B 5 Clutch head w/copper washers **6.00 R**

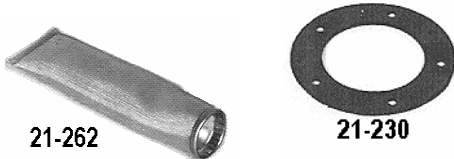

- 21-262 Gas Tank Sending Unit STRAINER, 5/16" **9.90 R**  
21-435 Gas Tank Sending Unit STRAINER, 3/8" **9.90 R**  
21-230 Gas Tank Sending Unit GASKET, all Cork/Nitrate ethanol resistant **3.00 R**

**Grp 21C Distributor, Coil & Tune Up**

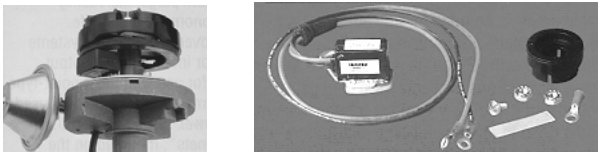

**IGNITOR® Solid State Electronic Ignition System**

Replaces ignition points and designed to be used with stock coil. Delivers twice the voltage to spark plugs. Fits entirely in the distributor, no moving or rubbing parts to wear out. 30 month Guarantee. Made by Pertronix. It is recommended that these be used with PER-40001 or 40011 Coils.

**Note!** Part numbers with LSC on end have lobe sensor technology that replaces magnet ring, cutting installation time to 15 minutes.

- 21-1168 54-62 '6' Cylinder **122.00 C**  
21-1181 57-74 V8 single point distributor **105.00 C**  
21-1181LSC 57-74 V8 single point distributor **113.00 C**  
21-1186LSC 55-6 V8 single point distributor (mechanical advance under base plate) **119.00 C**  
21-1182D 56-8 V8 dual point distributor (mechanical advance under base plate) **119.00 C**



- POINTS**  
21-310 55-56 V8 **15.00 R**  
21-314 57 V8 single points **11.00 R**  
21-317 6 cyl. **8.00 R**  
21-320 V8 w/dual points, Each **19.90 R**



- CONDENSER**  
21-311 55-56 V8, 57 w/dual point & 55-62 6 cyl **15.50 R**  
21-315 57 V8 single points **13.00 R**



- DISTRIBUTOR CAP**  
21-223 55-56 V8 all, 57 w/2 4's, FI **21.00 R**  
21-322 6 Cylinder **12.00 R**



- 21-32157-76, V8 w/window 2 & 4 barrel **19.50 R**



- ROTOR**  
21-224 55-6 V8 all, 57 w/2 4's, FI **7.95 R**  
21-224A 55-6 V8 all, 57 w/2 4's, FI **12.00 R**  
21-319 6 cyl. **7.85 R**

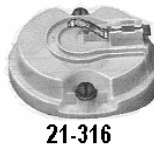

- ROTOR**  
21-316 57-76 V8 w/single points **7.00 R**

- 21-269C LEAD WIRE, 6 cyl Distrib. to Coil **8.00 R**  
21-269D LEAD WIRE, 57 V8 single points Distrib. to Coil **11.50 R**  
21-269E LEAD WIRE, 55-6 V8 single points Distr. to Coil **8.00 R**  
21-270 GROUND STRAP, *Distributor Points* **2.75 RP**



- 21-269F GROMMET, *Distrib. Wire* 57-74 V8 with 'window' distributor **2.50 R**  
21-269A GROMMET, *Distrib. Wire* 55-6 & 57 2-4s & FI (in distributor wall) **3.00 R**

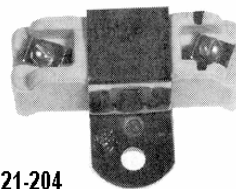

- Firewall BALLAST RESISTORS**  
21-204 55-6 all exc. H/P [blue dot] **28.80 R**  
21-204-1 57-64 all exc. H/P [blue dot] **28.80 R**  
21-302 All w/2 4's & FI [black dot] **30.00 R**



- Ballast Resistor COVER**  
 Polished Stainless  
30-3611 Plain **N/A**  
30-3612 Louvered **25.90**



21-45

**SPARK PLUGS**

- 21-R43S All except 57 with 6 cyl **3.50 RP**  
AC R43S, ea.
- 21-45 57 6 cyl AC R45, ea. **3.90 RP**

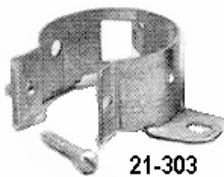

21-303



21-336A

**Coil Mounting Brackets**

- 21-303 2 & 4 barrel V-8, w/screw **20.00 R**
- 21-305 6 cyl. 1 bolt mount w/screw **9.75 RP**
- 21-336A 2 4's & FI, clamps around distributor as original **104.00 R**
- 21-306 Coil Bracket CLAMP SCREW, stainless **3.00 R**
- 21-308A V8 Coil Bracket Bolts pr w/locks Pr. **2.00 RP**
- 21-308B V8 Coil Bracket Bolts pr w/locks orig. 'E' headmark Pr. **3.00 R**

**Firewall mount Coil Brackets**

- PER-10001 COIL BRACKET for Ignitor coils, zinc plate **5.75 C**
- PER-10002 COIL BRACKET for Ignitor coils, chrome **9.80 C**

30-063A



- 30-063A Distributor Hold down, smallblock, chrome ea. **9.75**



21-242

**IGNITION COIL**

- 21-242 Replacement, black Spectra **22.00 RP**
- 21-242A Replacement, black StandardMP **31.00 RP**
- 21-242B Replacement, black StandardMP **21.00 RP**
- 21-059A 55-7 V8 (083) Discontinued
- 21-060A 56-7 2-4 Barrels (091) Discontinued
- 21-061A 57 Fuel Injection (107) new w/used original top **199.00 R**

**Pertronix Flame-Thrower Coils**

For Ignitor conversions, HEI & Electronic distributors

- PER-40001 Chrome 40m volt 1.5 ohm **52.00**
- PER-40011 Black 40m volt 1.5 ohm **52.00**
- PER-45001 Chrome 45m volt .6 ohm **52.00**
- PER-40511 Chrome 40m volt 3 ohm 6cyl **45.00**

PER-40001

**DISTRIBUTORS**

(Minimum clearance center of distributor to firewall required is 3.25")



21-406C

- 21-406C HEI Distributor small or big block, Pertronix 'Flame-Thrower". Adjustable vacuum advance. No misfires under 7500 RPM, produces 67% more coil energy spark break time 45% faster, twice the energy across the plug gap. This unit comes complete with coil as shown. **\$239.99**



21-406D

- 21-406D BILLET Distributor small or big block, 'Flame-Thrower" by Pertronix has vacuum advance. Internal Ignitor II electronic ignition module. Compatible with most coils or use with #Per-40001 or #PER-40011 Coils. Don't chance a No-name. **299.95**



21-406A

- 21-406A Stock Look Distributor cast aluminum housing, black window cap. Small or Big block w/adjustable vacuum advance & Pertronix Igniter technology **199.95 RP**
- 21-406 57 & UP V8 All single points, Rebuilt Replacement **N/A**
- 21-405 Stock 6 Cyl. Rebuilt, Exchange Only **150.00 RB**



21-365C



21-366B

Vacuum Advance Unit

- 21-365C 6 Cylinder 53-62 w/ shoulder screw **57.00 RP**
- 21-366B 55-6 V8, w/threaded fitting (new Repo) **47.00 R**
- 21-367RP 57-UP V8, RP slip on hose connection, adjustable **29.90 RP**



PER-D2000



PER-D3000

**HEI Performance Cap & Rotor**

- PER-D4000 Black **31.00**
- PER-D2000 Module **52.00**
- PER-D3000 COIL, Type A, replaces coils with red & yellow wires **51.00**
- PER-D3001 COIL, Type B, replaces coils with red & white wires **53.00**
- PER-D4001 Red **31.00**



23-162

- SPARK PLUG WIRE GROMMETS** for stock WIRE SUPPORT BRACKETS
- 23-162 V8 4 hole, Ea. **1.95 R**
- 23-163 V8 1 hole, Ea. **.65 R**



PER-08000



PER-D4051

HEI Distributor TUNE-UP KIT small or big block, Pertronix. Includes module coil combo, rotor & cap, coil cover, adjustable vacuum advance, advance kit, wire harness & capacitor.

- PER-D8000 Black **133.00**
- PER-D4050 CAP Black **25.00**
- PER-D8001 Red **133.00**
- PER-D4051 CAP Red **25.00**

### Repro SPARK PLUG WIRE SETS

V8 Original Plug Wire Sets **\$85.00 R**  
Reproduced exact original lengths,  
original boots and markings.



- 21-444 2 & 4 BARREL V8 55 & 56 Early (70° Black Plug Boots)
- 21-445 2 & 4 BARREL V8 56 2nd Design (90° Black Plug Boots)

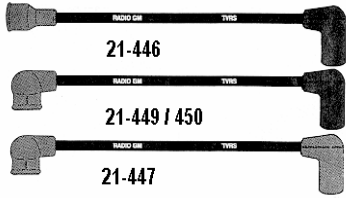

- 21-447 2 & 4 BARREL V8 57 (90° Plug & Dist. Boots Black)
- 21-446 DUAL 4 BARRELS V8 56 (90° Black Plug Boots)
- 21-449 DUAL 4 BARRELS V8 57 90° Orange Plug Boots, 90° Black Distr. Boots)
- 21-450 FUEL INJECTION 57 (90° Orange Plug Boots, 90° Black Distr. Boots)  
'6' Cylinder Original Plug Wire Sets **\$65.00 R**
- 21-451 6 cyl. Plug Wire Set 55-57

#### Delco REPLACEMENT SPARK PLUG WIRE SETS

- 21-256 6 cyl. set, Delco **36.00 RP**
- 21-323 55-7 V8 set, Delco **N/A**

#### Pertronix 'Flamethrower' SPARK PLUG WIRE SETS

8MM includes 90° distributor terminals for both male & female distributor caps. Universal Black V8 sets you cut to length & install distributor end of your choice **\$75.00**

- 21-255A V8 90° Spark Plug ends
- 21-255B V8 45° Spark Plug ends Black

#### Pertronix Stock Replacement

7mm Fully made up set 7MM 'Stock Look' original replacement; 90° plug boots, Strait distributor boots no scripts

- 21-255D 55-70 Smallblock Black **67.00**

### TAYLOR SPARK PLUG WIRE SETS

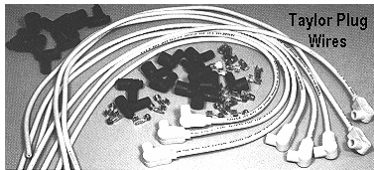

8mm Spiro Pro multi spark & electronic ignitions  
**\*Specify color** (black, red, yellow, blue, purple, orange, lime, white)

**\*Specify boot angle** (90, 135, degree) or specify rams horn exhaust manifolds or headers

- 30-TPW90B 90 degree black **\$84.00**



28-072 Spark Plug WIRE SHIELDS, LOWER, 57 under exhaust manifolds, Pr. **37.00 R**

### IGNITION WIRE SUPPORT KITS



28-004 55 V8, original **54.00 R**



28-005 56 V8, original **54.00 R**  
28-101 Spark Plug HEAT SHIELDS, 56 w/2 4's, Pr. Call Goat Hill Classics CA

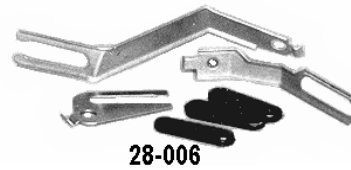

28-006 57 V8, Upper brackets **39.90 R**

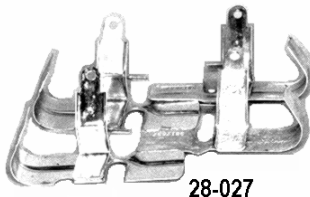

28-027 Spark Plug HEAT SHIELDS, 57 Set of 4 **29.95 R**

Billet & Smoothie Wire Looms & Separators  
**See Page 202**

### Grp 21D Generator / Starter



21-326 Generator BALL BEARING **6.50 R**



21-430 Generator OIL CAP, for 1/4" hole, as original, Ea. **3.50 R**

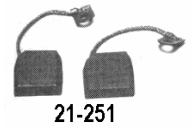

21-431 Generator OIL CAP, for smaller 3/16" hole, Ea. **2.50 R**

21-251 Generator BRUSHES, Pr. **12.00 R**



21-326A

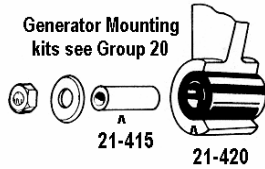

Generator Mounting kits see Group 20

21-415  
21-420

**Generator Restoration Kit**

Includes 2 terminal post, 2 brushes, 1 oiler assembly, 1 bearing, 1 bushing, 2 oil caps, hardware

- 21-326A Standard short or long generator **N/A**
- 21-326B Power Steering & 57 HiPo Generator as above but has 2 bearings **N/A**

- 21-415 SLEEVE for Generator mount bushing 21-420 Ea. **2.75 R**
- 21-420 Rubber BUSHING for generator mount, Ea. **5.50 R**



28-035  
16-124  
28-034

**Generator Mounting Bracket**

- 28-034 For 6 INCH Generator **23.75 R**
- 28-035 For 7 INCH Generator **24.50 R**
- 16-124 For POWER STEERING Generator. w/2 bushing mount 6 1/2" between mounting stubs **25.90 R**  
The 3 brackets for above are also available Used Call
- 16-124A Power Steering GENERATOR RELOCATION BRACKET  
Use to clear dual master cyl with booster. **21.95 RP**
- 16-120 Bushing HEAT SHIELD, Power Steering Generator **9.90 RP**
- 28-105 Generator PULLEY, w/Deep Groove, 3 5/8" 56-7 w/Hi-Lift cam, High Performance **N/A**



21-325D

**'PowerGen' Alternator**  
looks like a Generator.

90 Amp Internal Regulator, Powder coated, Aluminum half the weight of original generator. Long Case 7"

- 21-325A Black 1 wire **444.00**
- 21-325B Black 2 wire 2<sup>nd</sup> wire is for 'GEN' lamp in dash **444.00**

**Vintage Alternators** made in Canada

Looks like original 7" Generator as above & includes original power steering pump drive

- 21-325C Black 1 wire Long Case 7" w/ pump drive **579.00**
- 21-325D Black 2 wire Long Case 7" w/s pump drive 2<sup>nd</sup> wire is for 'GEN' lamp in dash **579.00**



28-075

**Generator Adjustment Brackets**

- 28-075 V8 Generator **34.00 R**
- 28-075U V8 Generator ,good used **25.00 RU**
- 28-076 6 cyl. Generator **19.50 R**
- 28-096 56-57 V8 with 2 -4 Barrels **N/A**
- 28-075A 56-57 V8 with 2 -4 Barrels Bracket above & Special Mount Bracket, Set **N/A**

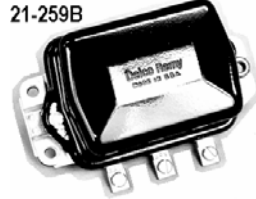

21-259B

**VOLTAGE REGULATORS**

- 21-259B 57 style cover, Delco, 55-6 Rp **85.00 GM**
- 21-424 Aftermarket Replacement 55-7 **Discontinued**



19-100

- 19-100 DELCO TAGS, original red & black tags for generator, starter & distributor, set of 3, unstamped **12.50 R**

**Delco Tag w/correct Serial Number & Date Code**

For number information see back of catalog or specify your choice, we can make them up any way you wish,

- 19-186 GENERATOR TAG, rivets included, ea. **20.00 R**
- 19-187 DISTRIBUTOR TAG, [exc. 57 window distributor] rivets included, ea. **20.00 R**
- 19-187A DISTRIBUTOR DELCO TAG, 57 V8 2 or 4 barrel made up w/correct info & datecode. Aluminum wraparound. You must specify code & tag will be made to order Call Paragon Repro. 810-655-4641
- 19-188 STARTER TAG, 55-6, rivets included, ea. **20.00 R**
- 19-189 DELCO TAG RIVETS, pack of 6 **1.50 R**

**NOTE: 19-186, 19-187, 19-188,** In order to make your tag correctly we will need to know the date code you wish. If you don't know we will need your VIN #. 57 V8 starters did not have a starter tag. The numbers were stamped directly into case. Specify if you have AC or power steering

**REBUILT GENERATORS**

Exchange send in your good core first. All external parts must be usable. We have few cores but we will do your unit. These are privately done for us to a high standard to provide you with a dependable quality part. All generators are painted semi-gloss black w/flat silver ends. Do not send in cores that are physically damaged, parts with broken ears, stripped threads etc are not acceptable cores. Be careful when sending these in so that they are not damaged in route. We are not responsible for your improper packing or shipping damage. Call for additional details

21-DETAIL Show Detailing Add **\$65.00** includes coded Delco Tag.



21-328A

- 21-327 6" solid mount, 55-6 **140.00**
- 21-327A 6" rubber mount, 57-62 '6' **140.00**
- 21-328 7" solid mount, 55-6 V8 **140.00**
- 21-328A 7" rubber mount, 57 V8 **140.00**
- 21-329A Pwr Steering rbr mnt. 57 **185.00**
- 21-377 Pwr Steering solid mnt 55 **145.00**

**REBUILT STARTERS**

Exchange. Send in your good core first. All external parts must be usable.



21-338A

STARTER w/solenoid Exchange **\$140.00**

- 21-330 55-6 original V8
- 21-331 57-62 original V8
- 21-332 57-62 V8 Hi-Torque
- 21-338 55-6 orig. '6' cyl
- 21-338A 57-62 orig. '6' cyl

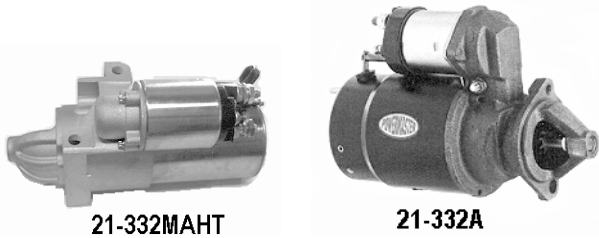

**High Torque MINI STARTER GM type \$159.00**

21-332MAHT for Big flywheel block mount has stager bolt pattern  
21-332MBHT for Small flywheel block mount has strait bolt pattern

21-332A STARTER V8 3 bolt Bell Housing mount. New Hi-Torque includes 57 & up style solenoid **169.00 R**

21-250A Starter REBUILD KIT, 55-6 orig. type 6 & V8 **52.95 R**

21-250B Starter REBUILD KIT, 57-64 all **44.95 R**



Starter CONVERSION PLATE to mount starter on orig. 265 blocks when changing to newer auto transmissions [283's have block mount holes]

21-START **\$ 179.00**



**21-258**



**20-482D**

21-258 Starter SUPPORT BRACKET, V8 front of starter to block **9.90 R**

**Block Mount Starter Bolts**

<u>20-482A</u>	3/8-16 x 1-7/8	<b>2.75</b>
<u>20-482B</u>	3/8-16 x 4-5/8	<b>3.90</b>
<u>20-482D</u>	Set of 3: 3/8-16 x 1-7/8, 3-5/8, 4-5/8	<b>6.90</b>



**21-252**



**21-253**



**21-407**

21-252 Starter SOLENOID, 55-56, original style open drive lever **59.00 R**

21-253 Starter SOLENOID, 57-79 **25.00 R**

21-407 Solenoid RUBBER BOOT 55-56 w/original solenoid, covers drive linkage. **4.50 R**

21-250 Starter BRUSHES, Set/4 **5.50 R**

21-268 Starter BUSHINGS, armature Std. Pr. **3.50 R**

**ALTERNATOR**

All are Internal Regulator Alternator Types

10si '68-82 The first internal type

**Alternator Bracket Notes** 21-440, 440-2, & -3 can be bolted to a stock exhaust manifold by filing out the front hole 1/4" to match the manifold threaded holes. Some shimming of alternator may be necessary to line up the pulleys. only. 20-440B brackets fit over the #1 cylinder header tube.

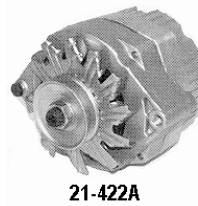

**21-422A**

21-422A Plain, 63 Amp all new **119.00**



**21-422B**

21-422B Plain, 85 Amp all new **137.00 USA**



**21-248**

21-248 Chrome, 90 Amp **150.00**



**21-248B**

21-248B Polished, 100 Amp 'Powermaster' wire connection toward inner fender when low profile mounted **169.00**

21-248B2 Polished, 100 Amp 'Powermaster' wire connection toward inner fender when low profile mounted **169.00**

21-248A Chrome, 63 Amp 'Proform' **149.90**

21-248C Chrome, 140 Amp 'Powermaster' **205.00**



**21-440**

**21-440-2**

**21-440-3**

**Alternator MOUNT Brackets**

21-440 Chrome use w/20-440B **18.75**

21-440-2 Black use w/20-440B2 **16.00**

21-440-3 Chrome with all necessary chrome bolts **24.00**

**Alternator HEADER Brackets**

21-440B Chrome use w/20-440 **16.00**

21-440B2 Black use w/20-440-2 **18.90**



**21-440B2**



**21-440A2**



**21-440C**

21-440A2 Alternator ADJUSTING BRACE Chrome **15.00**

21-440A3 Alternator ADJUSTING BRACE Black **15.00**

21-440C Alternator MOUNT FASTENERS; 18 pc Set **6.00**

AC Bracket listings See AC Section for prices. ALTERNATOR BRACKETS All brackets shown are driver's side mounting.

ALAN GROVE

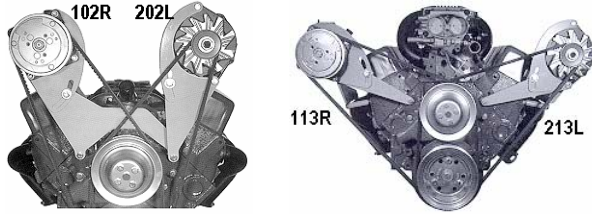

**SMALL BLOCK - SHORT WATER PUMP**

- AG-202LALT Over valve cover, extra clearance **103.50**
- AG-212LALT Tuned Port systems, tall over valve cover **113.50**
- AG-213LALT Low Profile, bolts to water pump **113.50**
- AG-213LALTLow Low Profile, 1" lower than AG\*213L **113.50**
- AG-232LALT Low Profile, Vortec Heads, Bolts to head /WP **113.50**
- AG-200LALT Over tall valve cover & intake, bolts to water pump & 2 ft intake bolts. Shorter than 202L **103.50**

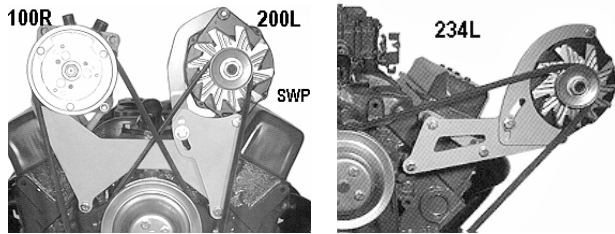

**SMALL BLOCK - LONG WATER PUMP**

- AG-201LALT Over valve cover, **103.50**
- AG-203LALT Over valve cover, use with 103RAC for multiple carb applications. Taller than 201 **103.50**
- AG-220LALT Tuned Port, over valve cover **113.50**
- AG-234L Low Profile, Vortec Heads, Bolts to head & water pump **113.50**

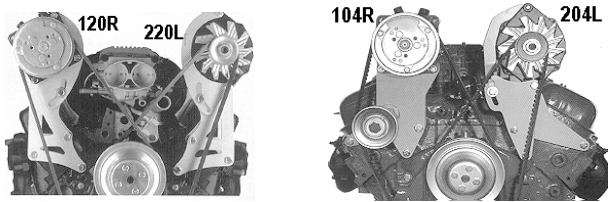

**BIG BLOCK - SHORT WATER PUMP**

- AG-204LALT Over valve cover **100.00**
- AG-218LALT Low profile **113.50**
- AG-221LALT Over valve cover Tuned Port or Multiple Carbs Taller than 204 **113.50**

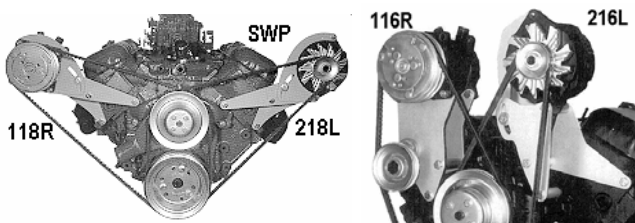

**BIG BLOCK -LONG WATER PUMP**

- AG-222LALT Low profile **113.50**
- AG-216LALT Over valve cover, belt runs in compressor groove & vice versa to clear water pump inlet hose, use w/116RAC **100.00**
- AG-224LALT **Alternator Brackets 55-62 6 cylinder 73.50**

**30-110A**

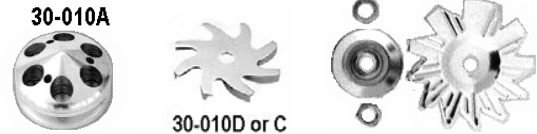

- 30-010A Alternator PULLEY, 1 groove (no fan) Satin **22.00**
- 30-010B Alternator PULLEY, 1 groove (no fan) Polished **33.00**
- 30-010BC Alternator PULLEY, 1 groove (no fan) Chromed **35.00**
- 30-010C Alternator FAN Satin aluminum **20.00**
- 30-010D Alternator FAN Polished aluminum **24.00**
- 30-010DC Alternator FAN Chromed aluminum **26.00**
- 30-110A Alternator FAN & PULLEY 1 gr. chrome **20.00**

**DAKOTA DIGITAL REMOTE CONTROLS**

6-12 Function Remote Accessory Controller

FROM DAKOTA DIGITAL

This product was engineered e word in mind flexibility! Providing up to12 channels of fully programmable outputs, the possibilities are endless. Common applications include Power windows, electric door locks, power trunk, tilt front ends etc. offering a limited lifetime warranty, the CMD-X also includes a pair of 6 button remote transmitters for ease of use! Code -hopping technology is built within the CMD-X for the ultimate in security. Several external relays are included to make installation simple and complete for any application.

CMD-X

**225.00**

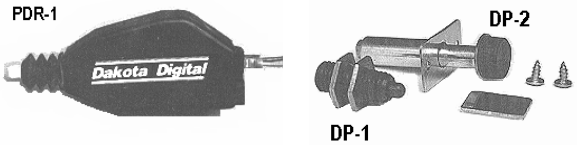

- PDR-1 Door Actuator 10 lb. of pull or push power, 1" of travel **39.95**
- PDR-2 Door Actuator 35 lb. of pulling power that increases to 30lb. At end of its 1 1/2" of travel. Sold each with a relay **84.95**
- DP-1 Door Poppers, spring loaded plunger for door areas with limited space, Pair body length 1-3/4" 5/16 stroke 25 lbs push force **34.95**
- DP-3 Super Door Poppers, spring loaded plunger with more throw Pair 1-1/2" stroke 3-9/16" depressed, 5-1/16" extended 25 lbs push force **54.95**

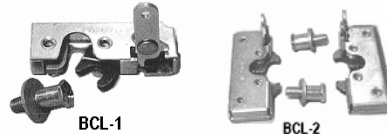

- BCL-1 Single Rotor Latch for trunk **38.00 each**
- Specify left or right*
- BCL-2 Double Rotor Latch Pr. for doors **65.00**

'Magnum Shooters' BUTTON CONTACTS

These eliminate wires in door jambs. Brass bullet type contacts are spring loaded & fully adjustable from 1/4 to 11/16", they are housed in a molded plastic housing.

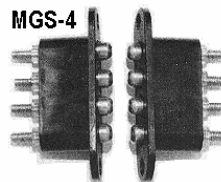

Uses include [but not limited to] Power Windows, Power Locks, Remote Entry Systems, Stereo Systems, Alarm Systems. Eliminate wire runs between Doors & Body, Trunks & Body, Tilt Front Ends etc. to Body, Requires drilling

Order 1 pair for each door.

- MGS-1 1 function, Pr. **16.95**
- MGS-2 2 function, Pr. **23.95**
- MGS-3 3 function, Pr. **29.95**
- MGS-4 4 function, Pr. **37.95**
- MGS-5 5 function, Pr. **44.95**
- MGS-4P 4 function, w/pin switch Pr. **44.95**

Grp 21F

**LOCKS**

Door Latch Mechanisms See Group 11 Door Area page **31**. Door Handle Mechanisms & Release Rods See Grp 20 Door page **107**



**21-243**

**COMPLETE LOCK SETS**

5 pieces, original bezels.

(2 doors, glove box, trunk & ignition) all except Wagons

- 21-243 55-57 All, exc. 56 Bel Air HT & Conv. **86.00 R**
- 21-243B 56 Bel Air HT and Convertible only **86.00 R**

**DOOR LOCKS, Pr.,**

- 21-244A 55 & 57 all, 56 exc B/A HT & Conv. Original **39.00 R**
- 21-244B 56 B/A HT & Conv. Original **39.10 R**

**DOOR & TRUNK LOCKS**

- 21-244C 55 & 57, 56 exc. B/A 3 pc. w/keys **48.00 R**
- 21-244D 56 B/A HT & Cv., 3 PC set w/keys **48.00 R**



**21-219**

- 21-219 Ignition LOCK CYLINDER & 2 Keys **16.50 RP**
- 21-240A BLANK KEY for Repro Locks, Each **4.00 R**
- 21-240 GM HEX KEY, blank **6.00 GM**



**21-243C**



**21-231**

- 21-243C 2 Dr. HT & Conv., 4 Dr. Sdn. & Wgn., Ea. **12.75 R**
- 21-243D Nomad, 2dr Sdn/Wgn/Sdn Deliv., 4dr HT, Ea. **11.50 R**
- 21-231 Glove Box LOCK RETAINER **3.90 R**



**21-245A**



**21-245B**



**20-260**

- 21-245 Glove Box LOCK ASSEMBLY stock w/key **25.00 R**
- 21-245A Glove Box Lock Assembly SMOOTH, no key **17.00 C**
- 21-245B Glove Box Lock SMOOTH, custom round flat bezel, for flat surface brush finish, no key, for custom console etc. **17.00 C**
- 20-260 Glove Box CATCH, for door, screws to dash **5.50 R**



**21-228**

**TRUNK LOCK**

- 21-246 Original Bezel, w/2 keys **20.75 R**
- 21-228 Replacement flat bezel w/2 keys **15.00 RP**



**21-246A**



**21-246C**

21-246A Trunk Lock RETAINER, holds lock in place **11.95 R**

- 21-246B Trunk Lock SHAFT, lock to mechanism in trunk lid **1.75 R**
- 21-246C Trunk Lock SHAFT SPRING hold shaft to lock **1.50 R**



**21-246F**

21-246F Trunk LATCH ASSEMBLY all exc wagons **99.00 RF**

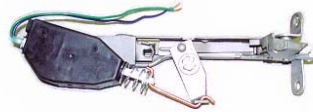

**21-246D**

21-246D ELECTRIC TRUNK RELEASE LATCH Exchange. An original trunk latch altered to include a solenoid, does not include switch, Ea. **180.00 C**



**21-246E**



**21-246G**

- 21-246G Trunk Lid Catch Plate, bolts to floor bracket **26.00 R**
- 21-246E Trunk LATCH COVER over latch in lid, Ea **26.00 R**
- 21-246EF Trunk Latch COVER foreign **17.80 RF**
- 20-011 LATCH to TRUNK SCREWS, screws to mount trunk lock mechanism to trunk lid, & for guide pin, Set **4.00 R**



**21-246H**

21-246H Trunk Lid Catch Plate & Lid Guide Pin Set new supplier [includes 21-246G & 11-13383] **45.00 RF**

**Door Lock RODS**

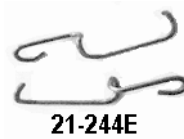

**21-244E**

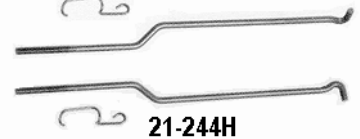

**21-244H**

- 21-244E Rod CLIPS, Pair **2.00 R**
- 21-244F Lock RODS w/clips HT's/Cv. Pr **11.00 R**
- 21-244H Lock RODS w/clips Sedans & Wagons Pr **11.00 R**
- 21-244G Lock RODS w/clips HT's/Cv. 56 Bel Air HT and Convertible. Key tumbler rods & clips **17.00 RF**

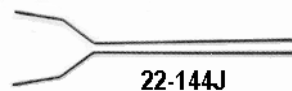

**22-144J**

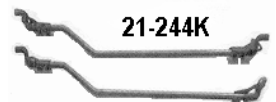

**21-244K**

- 21-244J Lock RODS Front Door 4D HT 56-7 Pr **11.00 R**
- 21-244K Latch to Handle RODS Rear Door 4D Sdn/Wgn Pr **10.00 R**



**21-244L**

Rear Door 4d Sdn/Wgn  
Lock & Handle Parts Each **20.00**  
21-244L Left 21-244M Right

**DOOR LOCK KNOBS**



**19-203D**

**19-203C**

STOCK Door Lock KNOBS Pr **\$6.90 R**

<u>19-204</u> Red	<u>19-205</u> Black	<u>19-206</u> Blue
<u>19-207</u> Green	<u>19-208</u> Turquoise	<u>19-209</u> Bronze
<u>19-210</u> Yellow	<u>19-209A</u> Tan	<u>19-209B</u> Gray

Billet ALUMINUM LOCK KNOBS

<u>19-203D</u> Billet Door Lock KNOBS Plain, Pr [Back Roads]	<b>35.00</b>
<u>19-203C</u> Billet Door Lock Knobs, original shape polished Pr	<b>26.00</b>

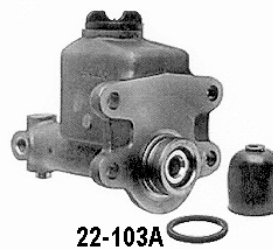

**22-103A**



**22-216**

**Stock MASTER CYLINDERS**

<u>22-216</u> ORIGINAL Restored/Rebuilt with original metal cap, cylinders is sleeved. Exchange Only	<b>299.00 RB</b>
<u>22-103</u> Reproduction w/brass block, metal cap, all original except no OE casting marks. Looks like 22-216 picture but without the Casting numbers & words	<b>125.00 R</b>
<u>22-103A</u> Replacement (Except Power) plastic cap	<b>N/A</b>

<u>22-102</u> Standard Master Cylinder OVERHAUL KIT	<b>24.00 R</b>
<u>22-123</u> RUBBER BOOT, Standard Master Cylinder Push Rod	<b>7.50 GM</b>
<u>22-218</u> Master Cylinder GASKET KIT, for original cylinder w/ metal cap, incl: firewall, cap & copper gaskets for brass block	<b>N/A R</b>
<u>22-217A</u> GASKET Master Cylinder to Firewall	<b>2.95 R</b>
<u>22-218A</u> COPPER WASHERS, for front brass block of original master cylinder, std. or power brake	<b>6.00 R</b>

**Grp 22**

**BRAKE PARTS**

**STOCK BRAKES**



**22-095**

22-095 Brake Pedal Shaft BUSHINGS, the large bushings that the brake pedal swings on [USA] Pair **11.00 R**

22-095D Brake Pedal SHAFT BUSHING [Danchuk version] Each **8.00 R**



**22-096**



**22-096A**

22-096 Pedal RETURN SPRING, brake pedal all models **11.00 R**

22-096A Pedal CLEVIS PIN, brake push rod to pedal, w/cotter **2.20 R**

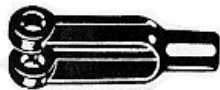

**22-096B**

22-096B YOKE, screws to pedal push rod, attaches to pedal q **7.00 R**



**22-102A**



**22-102A1**

Master Cylinder CAP  
22-102A exact original 55-61 with inner splash cap & original markings **24.50 R**  
22-102A1 replacement metal nut **8.95 RP**

22-217 Master Cylinder Cap GASKET, for metal cap **3.50 R**



**22-218S**

22-218S Original Master Cylinder Junction Block Set. manual or power. Incl.: block, 2 copper gasket, bolt **32.00**

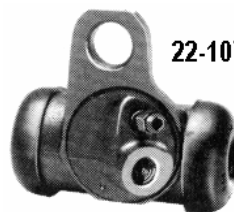

**22-107**

**WHEEL CYLINDERS**

<u>22-106</u> Front Left USA	<b>N/A</b>	<u>22-106F</u> Front Left	<b>28.00 RF</b>
<u>22-107</u> Front Right USA	<b>33.50 R</b>	<u>22-107F</u> Front Right	<b>28.00 RF</b>
<u>22-108</u> Rear Left	<b>12.00 RF</b>	<u>22-109</u> Rear Right	<b>12.00 RF</b>

22-111 REPAIR KIT Front **6.00** 22-112 REPAIR KIT Rear **6.00**  
22-109B Rear Wheel Cyl. mount bolts set/4 for both + locks **2.00**



**22-238**

22-238 WHEEL CYLINDER ROD, to Brake Shoe 2 required per wheel cylinder, Ea. **3.50**



**22-104N**

**BRAKE SHOES**

<u>22-104N</u> Front Wheel SET New	<b>33.00 R</b>
<u>22-105N</u> Rear Wheel SET New	<b>65.00 R</b>



**22-144B** SPINDLE WASHER flat lock washer for shoe pivot bolt **3.00 R**



**22-099** Brake Shoe GUIDE WASHER, goes over top anchor pin, over where shoes meet, 4 required per car, Ea. **4.50 R**



**22-124**



**22-213**

Adjuster HOLE PLUG  
**22-124** Rubber Ea. **.75 RP**  
**22-213** Metal Set /4 **4.00 R**



**22-140**

Brake Drums

**22-110A**

**22-110** Replacement, does not have spring groove that went around outside of original, Ea. **65.00 Rp**

**22-110A** Original with spring, Ea. **Discontinued**

**22-140** SPRING outside of orig. brake drum, Ea. **14.50 R**



**22-119**

**22-119** Flexible BRAKE HOSE, Front (2 required), Ea. **19.00 R**

**22-120** Flexible BRAKE HOSE, Rear, Ea. **20.00 R**

**22-135** COPPER WASHER, for stock front brake hose, Ea. **1.20 R**

Brake Shoe SPRINGS



**22-115**

**22-115** RETURN Springs 2 Wheels Set/4 **7.50 R**



**22-116**

**22-116** ADJUSTER Springs 2 Wheels, Pr. **4.00 R**



**22-117**

**22-117** SHOE HOLDDOWN Spring Kit 2 Wheels **6.75 R**



**22-133**

**22-133** ALL IN ONE KIT All Springs & Retainers, for 2 Wheels **12.00 R**



**22-118**

**22-118** Shoe ADJUSTER SCREW Assembly fits Front or Rear, Ea. **9.90 R**



**22-127**

Flex HOSE CLIP, Brake Hose to Frame Bracket  
**22-127** Each **2.00** **22-127S** Set of 4 **6.00**

**22-127C** Brake HOSE & E Brake CABLE CLIPS, Set/6,

[22-127B & 127S]

**8.80 R**



**22-133B**

Self-Adjusting Brake Hardware Kits

All hardware necessary to convert to self-adjusters

**22-133A**  
**22-133B**

All 4 drum brakes **95.00 RP**  
2 Rear drum brakes only **59.00 RP**



**22-212A**

**22-212A**

Front BRAKE LINE CLIP SET, 55 includes 3 strap clips w/screws to mount lines to frame **5.00 R**



**22-215**

Front BRAKE LINE CLIP, holds line to front frame crossmember, 2 required,

**22-215** Ea. **6.50 R** **22-215D** Pr. **12.00 R**

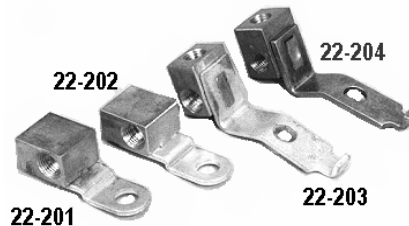

**22-201**

**22-202**

**22-204**

**22-203**

Brass Line 'T' Blocks Each **19.50 R**

**22-201** 55 Left Front

**22-202** 55 Right Front

**22-203** 56-7 Left Front

**22-204** 56-7 Right Front



**22-205**

**22-205** Rear Axle, all on rear, with clip

STOCK BRAKE LINES

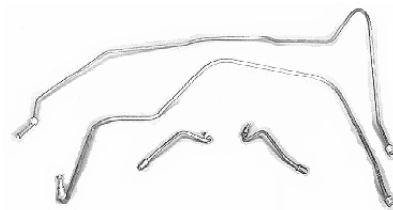

FRONT BRAKE LINE SETS

<b>22-169</b>	55	Manual 4pc	<b>49.00 R</b>
<b>22-223</b>	55	Manual 4pc Stainless	<b>65.00 C</b>
<b>22-170</b>	55	Treadlevac Booster 4pc	<b>49.00 R</b>
<b>22-224</b>	55	Treadlevac Booster 4pc Stainless	<b>65.00 C</b>
<b>22-168A</b>	55	HydraVac Booster	<b>49.00 R</b>
<b>22-168AS</b>	55	HydraVac Booster Stainless	<b>65.00 C</b>
<b>22-167</b>	56-7	Manual 4 PC.	<b>49.00 R</b>
<b>22-221</b>	56-7	Manual 4 PC. Stainless	<b>65.00 C</b>
<b>22-168</b>	56-7	Treadlevac 4 PC.	<b>49.00 R</b>
<b>22-222</b>	56-7	Treadlevac 4 PC. Stainless	<b>65.00 C</b>
<b>22-168B</b>	56-7	HydraVac Booster	<b>49.00 R</b>
<b>22-168BS</b>	56-7	HydraVac Booster Stainless	<b>65.00 C</b>

Treated steel tubing or stainless steel with double invert flares, pressure tested to 2,000 psi. Prebent to original shape and have spiral armor where applicable. Long Brake Lines are only available with one additional wide bend to allow them to be shipped by UPS (oversize). These are easily straightened back to proper shape when care is taken.

**LONG BRAKE LINES**

- 22-171 55 Outside frame 4 brl., Duals **35.00\* R**
- 22-228 55 Outside frame 4 brl., Duals Stainless **72.00\* C**
- 22-172 55 Inside frame 6 & 2 Brl., Single Exh. **35.00\* R**
- 22-227 55 Inside frame 6 & 2 brl., Single Exh. Stainless **66.00\* C**
- 22-173 56-7 Inside frame 6 & 2 brl., Single Exh. **35.00\* R**
- 22-225 56-7 Inside frame 6 & 2 brl., Single Exh. Stainless **71.00\* C**
- 22-174 56-7 Outside frame Dual Exhaust, 4b **35.00\* R**
- 22-226 56-7 Outside frame Dual Exhaust, 4b Stainless **65.00\* C**



**22-166**

**Rear AXLE BRAKE LINES on rear, Pr.**

- 22-166 Stock **25.00 R**      22-231 Stainless **45.00 C**
- 22-166A 3" narrow Ford 9" rears **25.00 C**
- 22-231A 3" narrow Ford 9" rears, Stainless **45.00 C**

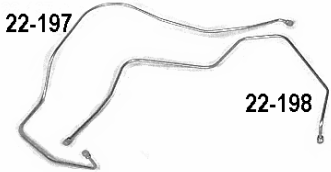

**22-198**

- Treadlevac Master Cylinder METAL LINE
- 22-197 55 **15.75**
  - 22-229 55 Stainless **43.00**
  - 22-198 56-7 **15.75**
  - 22-230 56-7 Stainless **35.00**

- 22-237 BRAKE LINE CLIP, holds master cyl. line to firewall, standard brakes [or use #20-498] NOS Each **7.00**

**ORIGINAL POWER BRAKES**

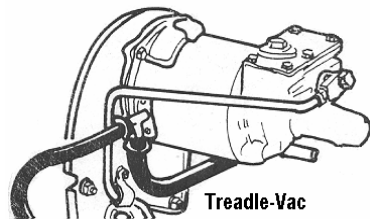

**REBUILT POWER BRAKE UNITS**  
We can only do your unit, It must be usable  
Call for details & pricing

- 22-194 55, Rebuilt
- 22-195 56-7, Rebuilt

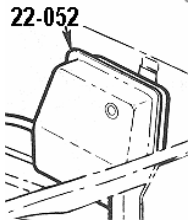

Power Brake VACUUM CANISTER  
nickel plated inside & out

- 22-051 55-6 **135.00 R**
- 22-052 57 **N/A**

**VACUUM HOSE KITS**

- 22-139A 55 w/clamps Treadlevac **21.95 RP**
- 22-139B 56-7 w/clamps Treadlevac **21.95 RP**
- 22-139C 55 w/clamps Hydro Vac **19.95 RP**
- 22-139D 56-7 w/clamps Hydro Vac **19.95 RP**

- 22-137 Vacuum HOSE, P/B 3/8" ID per foot **1.80 RP**

- 22-138 Vacuum Hose CLAMP, for P/B orig. type, Ea. **1.50 R**
- 22-217B CAP GASKET, for Treadlevac master cylinder **3.50 R**
- 22-050 DOUBLE SHOULDER BOLT, for Treadle Vac plunger rod to pedal **18.95 R**
- 22-101 LEATHER SEAL, Treadle Vac Vacuum Canister PistonSeal, Call Kanter Auto Products 800-526-1096
- 22-143 Accordion BOOT, for Treadlevac push-rod Call Kanter Auto Products 800-526-1096

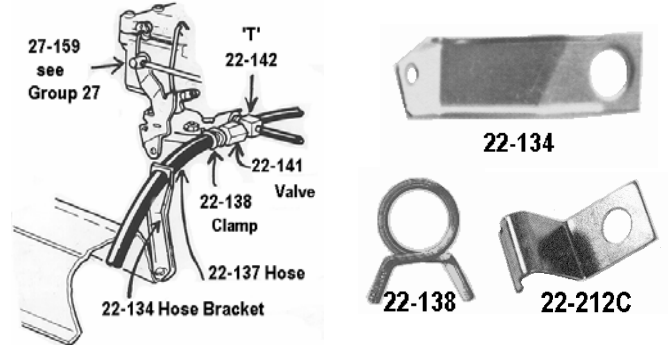

- 22-134 Vacuum Hose BRACKET for P/B on intake **10.90 R**
- 22-138S Vacuum Hose CLAMP SET Power Brake, Set/4 **4.00 R**
- 22-141 Power Brake vacuum CHECK VALVE **N/A**
- 22-142 Power Brake Check Valve BRASS 'T' FITTING, **39.50 R**
- 22-142A Power Brake Check Valve 'L' FITTING, back of stock carb to check valve, 2 pc replacement, cars w/ electric wipers **9.25 RP**
- 22-212B LINE CLIP Pwr/Brake line to firewall under booster **1.00 RP**
- 22-212C LINE CLIP Pwr/Brake line to firewall original **6.00 R**

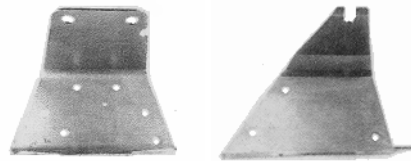

- Hydro Vac Booster BRACKET
- 22-053A 55-56 **65.00 R**
  - 22-053B 57 **65.00 R**

**EMERGENCY BRAKES**



**22-093**

Emergency Brake IDLER LEVER  
The front E-brake cable hooks to this under car

- 22-093 All exc. convert, **22.00 R**
- 22-094 Convertible, **22.00 R**



**22-091**

22-091 Emergency Brake Floor Brackets Pr., except convertible bolts to center floor brace under car in driveshaft tunnel **109.00 R**



**22-098**

ADJUSTING LINKAGE For 'E' Brake; Rod, Clevis, Horseshoe Assembly that rear cable rides in



**22-097**

- 22-098 Convertible **52.00 R**
- 22-097 All except Conv. **48.00 R**

20-558SS E Brake LINKAGE MOUNTING KIT, all bolts/nuts, washers to mount linkage from bottom of brake handle to floor & brackets to under body floor brace, stainless 57 pcs **22.00 RP**

20-558 E Brake LINKAGE MOUNTING KIT zinc plated **12.00 RP**

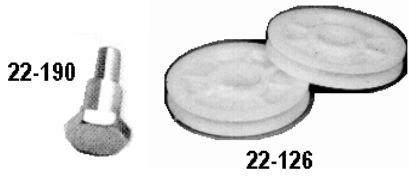

**22-190**

**22-126**

22-126  
Cable ROLLERS  
'E' Brake front cable  
[plastic] Pr. **11.75 RP**

22-190 SHOULDER BOLT for Brake Cable Roller, Pr. USA **6.60 R**



**22-126M2**

22-126M2  
Cable ROLLER SET steel w/  
shoulder bolts **27.00 RF**



**22-092A**

**22-092AC**

**E Brake HANDLE ASSEMBLY**

The complete assembly that bolts to dash & floor RF

- 22-092A 55-6 Stock Handle & 1 roller Golden Star **158.00**
- 22-092AC 55-6 Chrome Handle & 2 rollers DANCHUK **199.00**
- 22-092ACGS 55-6 Chrome Handle & 2 rollers Golden Star **188.00**
- 22-092B 57 Stock Handle & 1 roller Golden Star **158.00**
- 22-092BC 57 Chrome Handle & 2 rollers DANCHUK **199.00**
- 22-092BCGS 57 Chrome Handle & 2 rollers Golden Star **188.00**
- 12-197 Stock Chrome Handle only **32.00 RP**
- 12-197A Original Black plastic Handle only **23.00 R**

**Billet & other Handles see Page 61**



**22-098A**

22-098A **22.00 R**  
Front Cable CLEVIS BRACKET  
attaches front brake cable to Idler lever

22-233 CLEVIS PIN, front emergency brake cable to crossbar under car **1.70 R**



**22-121**

**FRONT 'E' BRAKE CABLE**

- 22-121 All except Convertible **18.80 R**
- 22-189 Convertible **24.00 R**



**22-122B**

**REAR 'E' BRAKE CABLES**

- 22-122B All, metal housing w/orig. smooth rubber boots **65.00 R**
- 22-122C All, metal housing USA made w/black cover **40.00 RP**
- 22-122C2 All, metal housing USA made no cover **44.00 R**
- 22-122F w/ 9" Ford Rear, Drum Brakes **80.00 C**



**22-122A**

22-122A RUBBER BOOT  
rear 'E' brake cable, Pr.  
original smooth type **5.25 R**



**22-235**

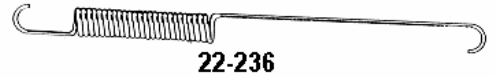

**22-236**

RETURN SPRING for 'E' Brake Linkage under car,

- 22-235 All models except convertible **13.00 R**
- 22-236 Convertible only **12.00 R**

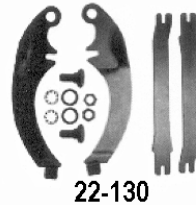

**22-130**



**22-129**

22-130 E Brake SHOE LEVER SET with crossbars and bolts **58.00 RF**  
22-129 'E' Brake CROSS BAR between brake shoes, 1 per side, Each **8.00 R**

22-193 SPRING for e-brake crossbar between brake shoes. Pr. **3.25 R**



**22-127B**

22-127B CABLE RETAINING CLIPS, to frame brackets, Pr. **5.00 R**

**LOKAR BRAKE CABLE PARTS Call for others**

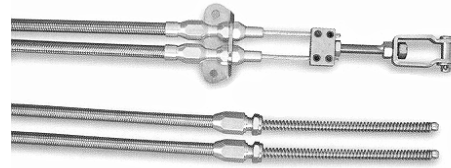

**L-EC80FHT**

Universal  
Emergency  
Brake Cables

Made to be used with connector cables above or Lokar floor mount hand brake. Kit includes stainless inner cable, 2 8' outer Teflon lined housings that "U- Cut-To-Fit". Will fit Ford or Chevy rear axle, drum or disc brakes. Kits can be ordered for special applications; Vette axle, Wilwood or Baer brakes Etc. Specify special need before ordering.

- L-EC80FU Black Housing **232.95**
- L-EC80FHT Stainless Housing **333.95**
- L-EC81FU Black Rear Disc Ford Explorer & Wilwood **232.95**
- L-EC81FHT Stainless Rear Disc Ford Explorer & Wilwood **333.95**



**L-EFB9003**

**Under Dash Foot Operated  
Emergency Brake**

Not a bolt-in. Dash to firewall adjustable bracketry, Connector cables sold separately **\$444.95**

- L-EFB9000 ball milled
- L-EFB9001 ball milled w/rubber insert
- L-EFB9002 window arm ball milled
- L-EFB9003 window arm ball milled pad rubber insert



**Connector Cables**  
for Under Dash Foot  
Operated E-Brake 6 feet  
long you cut to fit.

**L-EC8001U**

- L-EC8001U**
- L-EC8001HT**

Black housing **139.95**  
Stainless housing **205.95**



**L-EC80WC**



**L-EC80CC**

- L-EC80WC** E Brake CLEVIS CONNECTOR KIT for Wilwood & 88-up Vette Rear calipers. Cable to calipers **43.95**
- L-EC80CC** E Brake CLEVIS CONNECTOR KIT 84 to 87 Vette Rear calipers. Cable to calipers **56.95**



**L-EHB7000F**

**L-EHB7000F**  
Floor Mount 'E' Brake  
Handle Lokar **241.95**  
**L-EHB7000FX**  
Black **231.95**

**DUAL Master Cylinders for Stock DRUM Brakes**

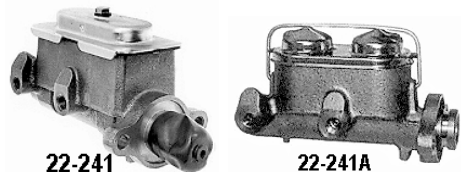

**22-241**

**22-241A**

**DRUM Brakes only**  
**22-241** Manual 1" bore **65.00**  
**22-241A** Power 1-1/8" bore **65.00**

**DRUM BRAKE to DUAL MASTER CYLINDER LINE KIT**  
Includes: 2 plugs, 1 "T", 2 adapters, 1 union, 4 lengths of strait brake line, 1 formed brake line, instructions. Strait lines need to be formed. Will work with manual or power brakes. Note; installing a dual master cylinder on a drum brake car will NOT improve braking, the only gain is the safety of the divided master.

- 22-241LK1** 55 **52.05**      **22-241LK2** 56-7 **52.05**

Below are Kits with 4 Lengths NiCop lines that are easier to form  
**22-241LK1NC** 55 **69.00**      **22-241LK2** 56-7 **69.00**

**16-124A** Power Steering Generator **RELOCATION BRACKET**  
Use to clear dual master cyl with booster. Moves generator up & in close to valve cover. if used up and in same belt can be used, if used down and out longer belt required. **21.95 C**

**Replacement BOOSTERS for 4 WHEEL DRUM BRAKES**

The Level mount booster will NOT clear stock power steering generator and pump. Use relocation #16-124A bracket in the power steering group with one of the Angle mount boosters below. These 7" single diaphragm boosters are for drum brake cars only. Do not use anything else on drum brake cars. Bolts to stock firewall master cylinder studs.

Use any of the boosters below with #22-241A master cylinder



**22-232D2**

Use on cars with original power steering generator and pump  
**22-232D2** 7" ANGLE Mount BOOSTER, zinc plated. **150.00**  
**22-232DC2** 7" ANGLE Mount Chrome BOOSTER w/stainless brackets **165.00**

- 22-232D1** 7" LEVEL Mount BOOSTER, matching brackets. **125.00**
- 22-232DC** 7" LEVEL Mount Chrome BOOSTER w/stainless brackets **145.00**

**DISC BRAKES**

**Important Tech Notes on Disc Brake Conversions.**

Please read

**NOTE 1 STOCK 57 14" Wheels CANNOT BE USED WITH DISC BRAKES.** You will need to take them from a later year that had disc brakes from the factory such as a 78-85 Malibu, then add [weld] the 4 bumps necessary on each wheel to hold the stock 57 wheel covers. See also the repro replacement wheels in Group 10 that can be used with disc brakes and the stock wheel covers.

**NOTE 2 Front Disc Conversion with original Rear Brakes.** We have experienced a few cars with stock rear brakes where the rear brakes lock up too easily. We feel this may be due to the larger diameter of the stock wheel cylinders among other things. We now supply an adjustable valve in our kits that takes the place of the stock passenger side brake line block, part # 22-234E. It is recommended that you add the self-adjusting kit #22-133B.

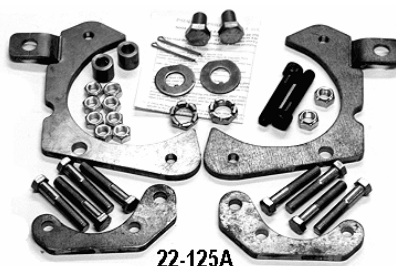

**22-125A**

**Front Disc Brake Adapter Kit,**  
Front caliper mounting brackets & hardware to mount the large GM 'A' body 69-77 7" calipers behind stock spindle

**22-125A Disc Brake Adapter Kit.** This is a well engineered kit without the annoying little problems from other manufacturers. It is a 2-piece mount made so that it is not necessary to adjust tie rods shorter as is necessary with all 1-piece adapters that move the steering arms in. Takes the biggest OE caliper and is the easiest installation. Made in USA [most others are not] moves wheel out 3/4" **165.00**

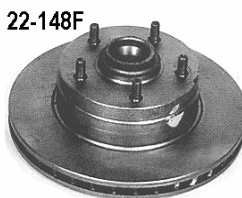

**22-148F**



**22-148SDP**

**Rotors**

*Front Disc Brake Conversion, use with #22-125A*  
Includes bearing races 4 3/4 bolt pattern, 10.9" dia.

- 22-148F** Stock spindle disc brake conversion. Each **77.00\***
- 22-148SDP** Slotted, Drilled & Plated. Directional Left & Right. add as an option to kits for \$50.00. Pair **160.00\***



**22-151**

**22-150**

**Rotor Bearings**

- 22-150** INNER w/race [A2] **12.00**
- 22-150A** INNER bearing only. **9.85**
- 22-151** OUTER w/race [A6] **11.00**
- 22-151A** OUTER bearing only **9.85**

- 22-152**
- 22-157**

Rotor GREASE SEAL [22-148F, 148SDP] **5.00**  
Rotor GREASE CAP, ea. [22-148F, 148SDP] **5.00**

- 22-144** SPINDLE NUT for Disc Brake Adapter, thin nut necessary for cotter pin installation if you do not wish to reverse stock nut, included in our 22-125A Adapter Kit. Ea. **Use 22-144C**
- 22-144C** SPINDLE NUT Set for Disc Brake Adapter, 2 thin nut, 2 washers 2 cotter pins **20.00**

**22-192B**

Caliper Hose Bolts Each



22-192 7/16-20 1" Long for/ 22-149 **7.00**

22-192B 7/16-20 7/8" Long for 22-149-1 **7.00**



**22-191**

22-192A 10-1.5 metric 7/8 long for 22-149C1 **6.50**

22-192A1 10-1.5 metric 1-1/16" long **6.50**

22-191 COPPER WASHER, Brake Hose to Caliper, 2 required per hose, sold Each **1.30**

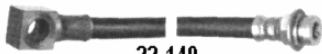

**22-149**

Caliper Flex Hose

22-149-1 7/16" thick boss [front caliper 22-125A kits] use w/22-192B or 22-192A bolt Each **19.90**

22-149 9/16" thick boss [front caliper 22-125A kits] use w/22-192 hose bolt Each **19.90**

22-149C1 7/16" thick boss, use w/22-192A [metric] hose bolt. Each **19.90**



**WW220-11372**

WW220-11372 Braided Stainless BRAKE HOSE SET for 7" GM calipers above. Pair includes hoses adapters, copper washers, banjo bolts [7/16-20] and frame bracket clips. 16" Long **93.00**



**22-147N**

Disc Brake CALIPERS

A' body type 69-72, new casting. This is the best performing OEM caliper for 55-7. Used originally on cars that were similar size & weight. 2.937" piston dia. 7" between the mount bolts

Versions were used on full size pickups in the '80s. 'Loaded'; pads bolts etc.  
LEFT RIGHT

<u>22-146N</u> Unpainted <b>79.00</b>	<u>22-147N</u> Unpainted <b>79.00</b>
<u>22-146NB</u> Black powder coat <b>N/A</b>	<u>22-147NB</u> Black powder coat <b>N/A</b>
<u>22-146NR</u> Red powder coat <b>N/A</b>	<u>22-147NR</u> Red powder coat <b>N/A</b>

Disc Brake Pads

22-153 Premium, for #22-146/147 calipers **22.00**  
22-153M High Performance Carbon Metallic pads **59.00**



**22-154**

22-154 Caliper BOLTS, 1 side (2) for #22-146/147 calipers **7.50**

22-155 Brake PAD RETAINERS, ea. #22-146/147 calipers **3.50**

22-156 Caliper HARDWARE KIT, 1 wheel, 22-146/47 calipers **7.25**



**22-155**

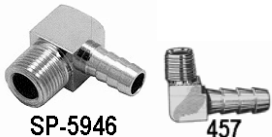

**SP-5946**

**457**

Vacuum Fittings

SP-5946 90° 3/8 NPT Male x 3/8 ID barbed Hose End Chrome **8.75**

457 90° 1/4 NPT Male x 3/8 ID barbed Hose End Brass **6.00**

See end of Group 20 for full list of fittings

Disc Brake BOOSTERS

Technical Notes; **Please Read**

All the Boosters on this page are for Disc Brake cars. Drum brake cars use only the 7" single diaphragm boosters shown on page 144. The Level mount boosters will NOT clear stock power steering generator and pump. Use relocation bracket 16-124A offered in the power steering group with angled mount booster. The 8" dual diaphragm is the standard in our power disc kits. All boosters require 18" vacuum for proper operation.

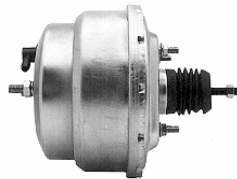

**22-232DD**



**22-232DD1B**

8" DUAL DIAPHRAGM BOOSTERS

The best booster for modified cars with disc brakes, Bolts to stock firewall master cylinder studs, instructions. Disc Brakes Only Booster and Brackets are Yellow Zinc plated

22-232DD 8" DD Booster only **145.00**

22-232DD1B 8" with Level Mount Brackets **183.85**

22-232DD2B 8" with Angle Mount Brackets **185.00**

22-232DD3B OFFSET Mount Booster Assembly 8" DD, moves booster UP 2" includes dual master cyl. 2 or 4 whl Disc brake cars only. Max valve cover clearance for big block w/tallest valve cover **N/A**

BOOSTER OPTIONS

**ANGLED mount:** Master cylinder is 7" from firewall & rises up toward front. Maximum amount of valve cover clearance. Recommended: use with Big Block applications. Requires a hole to be drilled in brake pedal 1" below stock hole.

**LEVEL mount,** Master cylinder is 5 1/4" from firewall. Recommended for Small Block applications

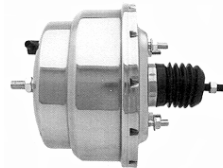

**22-232DSS**

STAINLESS & CHROME BOOSTERS

DUAL DIAPHRAM Stainless or Chrome brackets Disc Brakes Only.

22-232DSSB 7" DD Booster only SS **169.00**

22-232DSS 7" w/ Level mount SS **195.00**

22-232DSS2 7" w/ Angle mount SS **199.00**

22-232DD-C 8" DD Booster only Chrome **165.00**

22-232DD1B-C 8" w/ Level mount Chrome **203.85**

22-232DD2B-C 8" w/ Angle mount Chrome **205.00**



**22-232DD-PC**

Black Powder Coat Boosters DUAL DIAPHRAM

22-232DD-PC 8" Booster only **155.00**

22-232DD1BPC 8" w/Level Mnt Brackets **193.85**

22-232DD2BPC 8" w/Angle Mnt Brackets **195.00**



**Booster ROD EXTENSIONS**  
22-248A 3" stud, 3/8-24 for 22-247A **8.00**  
22-248B 3.5" stud, 3/8-24 for 22-247B **8.00**

**Booster Brackets to firewall Pair**  
22-247A Level mount 1-5/8" deep. Yellow Zinc **19.00**  
22-247ASS Level mount 1-5/8" deep Stainless Steel **30.00**  
22-247A-PC Level mount Black powder coat **23.00**  
22-247B Angle mount Yellow Zinc **19.00**  
22-247BSS Angle mount Stainless Steel **36.00**  
22-247B-PC Angle Mount Black powder coat **22.00**

**DUAL MASTER CYLINDERS**  
for 2 wheel or 4 wheel DISC BRAKES



**OEM Master Cylinders**  
 1/2-20 & 9/16-18 ports Front or 4 wheel Disc **\$59.00**  
22-243A Manual, 1" bore  
22-243 Power, 1-1/8" bore

22-243D GASKET 22-243, 243A master cyl cap **9.00**  
22-243E Master Cylinder Chrome Cover for 22-243, 43A **16.00**

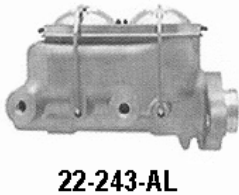

**Aluminum Master Cylinder**  
 1/2-20 & 9/16-18 ports  
22-243-AL Aluminum Dual Master Cylinder 1-1/8" bore [power] **89.00**  
22-243A-AL Aluminum Dual Master Cylinder 1" bore [manual] **89.00**



**WILWOOD aluminum DUAL MASTERS**

7/8" Bore Manual applications. 1" Bore Power applications.  
WW260-9439 7/8" Natural **250.00** WW260-8555 1" Natural **250.00**  
WW260-94392 7/8" Bright **299.00** WW260-8555P 1" Bright **289.00**  
WW260-9439BK 7/8" Black **299.00** WW260-8555BK 1" Black **289.00**



**Master Cylinder & Adjustable Proportioning Valve Set**  
 7/8" bore Manual brakes only  
WW261-13271 7/8" Natural **399.00**  
WW261-13271P 7/8" Bright **440.00**  
WW261-13271BK 7/8" Black **440.00**  
WW261-13269 1" Natural **399.00**  
WW261-13269P 1" Bright **440.00**  
WW261-13269BK 1" Black **440.00**

22-245A BENCH BLEEDING KIT for Dual Master Cylinder Universal with instructions **3.50**

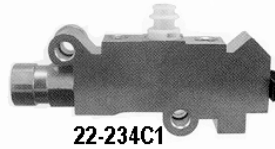

**GM style Proportioning Valves**  
For disc brakes & dual master cylinders **69.00**

22-234C1 Front disc brakes, brass  
22-234C2 4 whl. disc, brass  
22-234C1A Front disc brakes, aluminum  
22-234C2A 4 whl. disc, aluminum  
22-234C2A 4 whl. disc, chrome **80.00**



**Proportioning Valve Brackets**  
Locates valve below master cylinder for GM type valves Each **12.00**  
22-232G Power Disc  
22-240G Manual Disc



**Residual Pressure Valve**  
22-234M1 2 LB **12.00**  
22-234M2 10 LB **12.00**  
 For drum brake rears to maintain shoe spring pressure as required

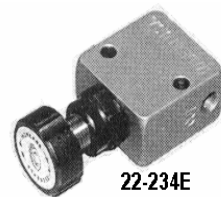

**Adjustable Proportioning Valve**  
22-234E Up to 60% reduction over the full pressure range, brass internals, supplied with inverted flare tube adapters, can be mounted in place of right front brake block. Use for premature rear brake lock-up **55.00**

22-234F Adjustable Valve BRACKET for 22-234E above puts valve in place of right frame T fitting **9.00**



**Adjustable Proportioning / Metering Valve #22-234MB** Black  
 Configuration similar to GM valve but adjustable. These valves come with 3/16 Line Inverted Flare female ports with tubing nuts supplied and one 3/16 to 1/4 line adapter for rear line out. Standard domestic inverted flare brake lines. Each **49.00**

**Brake Line Adapters** For Brake Line to Dual Master Cylinders

22-7908 1/4" Line [7/16-24] to 9/16-18 Hole **4.75**  
22-7908A 3/16" Line [3/8-24] to 9/16-18 Hole **4.90**  
22-7909 3/16" Line [3/8-24] to 1/2-20 Hole **4.90**  
22-7909A 1/4" Line [7/16-24] to 1/2-20 Hole **4.50**  
22-7023 Brass 'T' inverted flare 3/16" lines **7.00**  
22-7765 Brass 'T' inverted flare 1/4" lines **9.00**  
22-7907A 1/4" line [7/16-24] to 3/8-24 Hole **4.50**

**Brass Inverted Flare Fittings**  
69 Union 3/16" Line **2.00** 70 Union 1/4" Line **2.00**  
72 Union 3/8" Line **4.60**



36 Inverted Flare Nut for 3/16 tube Steel **1.00**  
37 Inverted Flare Nut for 1/4 tube Steel **1.10**

**Male Connector**  
50 1/8 NPT to 3/16" Line **2.00**  
27-163 1/8 NPT to 1/4" Line **4.00**

**Adapters** National Pipe Thread (NPT) to -AN to standard Brake lines

<u>22-A1</u>	Hose Adapter 1/8 NPT to 3AN Strait Each [6956]	15.00
<u>22-A2</u>	Hose Adapter 1/8 NPT to 3AN 45 Each [6412]	15.00
<u>22-A3</u>	Hose Adapter 1/8 NPT to 3AN 90 Each [13125]	15.00
<u>22-A4</u>	Line Adapter -3an Male to 3/16 brake line Female Each	14.00
<u>10-075HC1</u>	Line Adapters for Wilwood Kits adapts 3/16 steel lines to 3an braided hoses.	28.00



**WW220-7699** BRAIDED FLEX HOSE Set 16" w/adapters **87.00**

**Brake Flex Hose & Flex Hose Kits**

<u>22-AH12</u>	Female 3an Flex Hose 12" Each [8762]	29.
<u>WW220-11237</u>	Rr 3an Flex Hose 22" Kit w/ adapters	79.
<u>WW220-12630</u>	Rr 3an Flex Hose 10" Kit w/ adapters	93.
<u>10-075HC</u>	Female 3an Flex Hose for Wilwood Brake Kits Pr	59.

**We stock : NYCOP tubing, Tubing flare Nuts & Strait lengths of Steel & Nycop Lines 6 to 24 inch long & all manner of adapters**

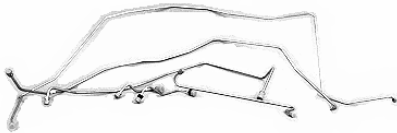

**Prebent DISC BRAKE LINE SETS**

All line kits are 6 piece sets that 'Bolt-In' w/correct size line & ends for disc brake conversion, using the 2 original front brake line blocks. Includes all the metal lines necessary from dual master cylinder to the original brass block that feeds the long rear brake line. The flexible rubber hoses for the front wheels are NOT included. Kits require master cylinder, which uses the front reservoir for front wheels, rear reservoir for rear wheels. Detailed instructions are supplied. Some applications may require slight adjustment of the lines; if directions are followed these lines can be installed in MINUTES. USA made

**MANUAL Front Line Sets for disc brakes set of 6**

For Manual Dual Master Cylinder bolted directly to firewall

<i>Steel</i>	<u>22-240A</u> 55	<u>22-240B</u> 56-7	<b>80.00</b>
<i>Stainless Steel</i>	<u>22-240AS</u> 55	<u>22-240BS</u> 56-7	<b>114.00</b>

22-239 LINES, Prop Valve to Dual Master Cylinder, Universal, These have correct fittings for master cyl **19.90**

**POWER Front Line Sets for disc brakes set of 6**

For Dual Master & **Booster Angled up at front**. 6 3/4" or greater from back of master cylinder to firewall. Use with booster #'s; 22-232DD2B, DD3B, DSS2, DSS4

<i>Steel</i>	<u>22-232E</u> 55	<u>22-232F</u> 56-7	<b>80.00</b>
<i>Stainless Steel</i>	<u>22-232ES</u> 55	<u>22-232FS</u> 56-7	<b>114.00</b>

For Dual Master & **Booster Mounted Level**. 4 1/2" to 6 3/4" from back of master cylinder to firewall. Use with booster #'s; 22-232DD1B, DSS1, DSS3

<i>Steel</i>	<u>22-246E</u> 55	<u>22-246F</u> 56-7	<b>80.00</b>
<i>Stainless Steel</i>	<u>22-246ES</u> 55	<u>22-246FS</u> 56-7	<b>114.00</b>

<u>22-166A</u>	Rr Axle Brake LINES 3" Narrowed Ford 9" Pr Steel	<b>25.00</b>
<u>22-231A</u>	Rr Axle Brake LINES 3" Narrowed Ford 9" Pr Stainless	<b>45.00</b>

**For other lines see page 142**

**DROPPED SPINDLES**

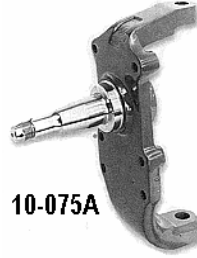

**10-075A**

**10-075A 2" DROPPED SPINDLES**

Steel by Heidt's 'bolt on' caliper mount, mounts big 69-77 'A' body 7" calipers 2.937" piston dia. The best, copied many times but these are made of 1045 heat-treated alloy steel. Pr. **566.00**

**10-075A1 2" DROPPED SPINDLES**

without caliper brackets [Wilwood or ECI brake kits] Each **274.** Pr **548.**

**Dropped Spindle WHEEL KIT for Heidt's Spindles**

Includes 10.5" rotors, calipers, bearings, hoses & hardware to complete installation of #10-075A spindles. These spindles use A3 & A6 bearings that require use of 80 Malibu rotors that are supplied with this kit. Stock spindle kits use A2 outer bearings. 10-075B kit w/Big 2.937" piston 69-77 Chevelle Calipers **445.00**  
10-075B1 Kit for those who already have stock spindle disc brake kit provides rotors & associated parts so you can use your current calipers. Without disconnecting them. **CALL**

'O' OFFSET Dropped Spindle WHEEL KIT for Heidts Spindles with 13" OEM Vette Rotors & the same big 2.937" piston Calipers used in our regular kits. 'O' Offset accomplished with custom made aluminum hubs included 17" or larger wheels **22-EC73513 980.00**



**WW140-12307ZR**

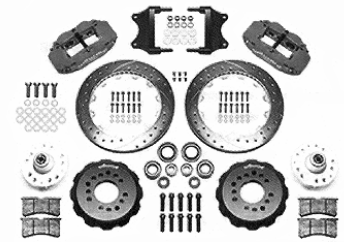

**Wilwood 13" Rotor Front Brake Kit**  
For Heidts Dropped Spindles

17" or larger wheels

12.88" Rotors 1.1" thick, Forged narrow 6 piston Calipers. Minimal offset. Use with WW220-7699 Hose Set. Special Order

<u>WW140-12307DR</u>	Black Drilled & Slotted Rotors, Red Calipers.	<b>Call</b>
<u>WW140-12307D</u>	Black Drilled & Slotted Rotors, Black Calipers.	<b>Call</b>
<u>WW140-12307R</u>	Plain Rotors, Red Calipers.	<b>Call</b>
<u>WW140-12307</u>	Plain Rotors, Black Calipers	<b>Call</b>

**Wilwood Heidts Dropped Spindle Kits also made**

WW140-12305 4 piston 11" rotor WW140-12306 4 piston 12" rotor  
Black or Red Calipers, Plain or Drilled & Slotted Rotors  
Special Order **Call**

We can help and offer other possibilities besides those listed. Each car is different. We can tailor a 'Kit' for your particular car. Your combination of parts: engine, trans, suspension, wheels, etc. may require something different from what you have in mind. Contact us.

**STOCK SPINDLE DISC BRAKE WHEEL KITS**

Be sure to READ Technical Notes at the Beginning of the Disc Brake section. If you are buying for price be sure to check what you are getting for the money when comparing. Our kits offer USA made brackets & brake lines and branded rotors, calipers & bearings. In our standard kits we use only the LARGE PISTON 69-77 GM 'A' body OEM type calipers (7" center to center on mount bolts), the ONLY one that works well on 55-7. Added cost options available besides what is shown here. Contact us



**22-145A**

**22-145A** Stock Spindle, includes 2 New 'loaded' (w/pads and hardware) OEM 7" single piston calipers, 2 rotors 10.9" dia., #22-125A 2 pc adapters, bearings, seals, grease caps 2 flex hoses, everything needed at the front wheels, moves wheel out 3/4" **442.30**



**22-EC70**

Stock Spindle '0' offset Wheel Kits **22-EC70BACK** Includes 2 new 7" single piston calipers, pads, brackets, bearings, & seals, 11" hat rotors & special aluminum hubs giving '0' offset **850.00**  
**22-EC70BACK13** Kit with 13" Rotors 17" wheels **950.00**  
**22-149C** Hoses w/bolts for above. **49.90**



**WW140-11491**

Stock Spindle **WILWOOD** Kits  
 4 piston 11 or 11.75 inch rotors .30 offset less than 5/16", or 6 piston 12.19 rotors .23 offset less than 1/4". Black or Red Calipers, Plain or Drilled & Slotted Rotors. Special Order

**55-7 Stock Spindle Minimum 15" Wheel**

- |                       |  |             |
|-----------------------|--|-------------|
| <b>WW140-11491</b>    | 11" Plain rotor Black 4 piston caliper         | <b>Call</b> |
| <b>WW140-11491-R</b>  | 11" Plain rotor Red 4 piston caliper           | <b>Call</b> |
| <b>WW140-11491-DR</b> | 11" Drilled/Slotted rotor Red 4 piston caliper | <b>Call</b> |
| <b>WW140-7676</b>     | 12" Plain rotor Black 4 piston caliper         | <b>Call</b> |
| <b>WW140-10737</b>    | 12" Plain rotor Black 6 piston caliper         | <b>Call</b> |
- Call for Others

**STOCK SPINDLE MANUAL Front Disc Brake COMPLETE Kits**

Everything needed including our 22-145A wheel kit, 22-243A master cylinder, 22-234 proportioning valve & mount, & one of our 22-240 series formed line kits. Moves wheel out 3/4" NO SURPRISES!!!

		List	Selling Price
<b>22-145C1</b>	55 w/steel line kit	<b>[867.08]</b>	<b>765.09</b>
<b>22-145C1S</b>	55 w/stainless line kit	<b>[901.58]</b>	<b>794.39</b>
<b>22-145C5</b>	56-7 w/steel line kit	<b>[865.53]</b>	<b>763.54</b>
<b>22-145C5S</b>	56-7 w/stainless line kit	<b>[901.58]</b>	<b>794.39</b>

**Front Disc Brake Kit OPTIONS**

- ADD TO #22-145, #22-345 or #22-346 KITS where applicable Call for Other
- |                    |   |               |
|--------------------|---|---------------|
| <b>22-OPTION-5</b> | BLACK Powdercoat Booster to replace Zinc Booster        | <b>+\$20.</b> |
| <b>22-OPTION-4</b> | CHROME Booster to replace Zinc Booster                  | <b>+\$25.</b> |
| <b>22-OPTION-5</b> | Drilled & Slotted Rotors INSTEAD of standard rotors     | <b>+\$50.</b> |
| <b>22-OPTION-6</b> | Wilwood Master Cylinder INSTEAD of standard master cyl. | Call          |
| <b>22-OPTION-7</b> | Bright Wilwood Master INSTEAD of standard m/cyl.        | Call          |

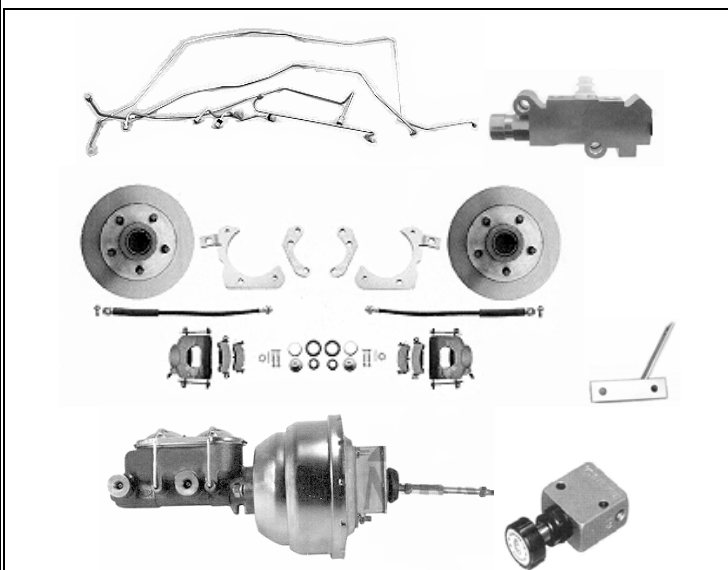

**STOCK SPINDLE POWER Front Disc Brake COMPLETE Kits**

*Notes:* the wheels will be moved out 3/4" per side. As long as you use wheels no wider than 7" with a 3.75" offset and tires no larger than 25.5" diameter this should not cause any problems. For example a 215/50R17 is 25" diameter, a 215/65R15 is 25.5" diameter. If you can see the whole tire when the car is at rest you won't have many if any problems only things like turning with a hard cut into a parking lot with a deep gutter along the curb. If the tire is up underneath the fender lip you will have problems so this should be avoided.

If you wish to use stock wheels & Hubcaps we have wheels for this see page 20.

The lines sets used [page 147] use the 2 original line blocks; this helps locate the lines and keeps them from moving around and allows the use of stock lines to the rear. They are not included. If you will need them see page 142.

**STOCK SPINDLE Everything needed**

Includes our 22-145A wheel kit, our 22-232DD Zinc Plated 8" Dual Diaphragm Booster w/brackets, 22-243 or 22-243A master cylinder 22-234 prop. valve & mount bracket, an adjustable valve & a Formed Line Kit according to your year & engine.

There is no kit more complete or easier to install. No bending of universal lines, 2 pc caliper brackets remove the need to shorten tie rods & realign front end. All necessary hardware. NO SURPRISES!!! [The only extra requirement is to drill 1 hole in your brake pedal if using the Angled booster] When installed it Looks RIGHT!

You can use the angle mount kit on any application if you wish. 'Small Block' includes LS engines use Level Mount Booster, 'Big Block' use Angle Mount Booster. You can use the Angle Mount on the Small Block if desired, it gives more clearance for valve covers especially an issue on Big Blocks. If you have original generator with power steering pump attached use 'Big Block' kits.

		List	Selling Price
<b>22-345L</b>	55 Small Block V8 steel line kit	[1080.]	<b>967.95*</b>
<b>22-345LS</b>	55 Small Block V8 stainless line kit	[1116.]	<b>1002.78*</b>
<b>22-345A</b>	55 Big Block V8 steel line kit	[1060.]	<b>949.12*</b>
<b>22-345AS</b>	55 Big Block V8 stainless line kit	[1102.]	<b>985.42*</b>
<b>22-346L</b>	56-7 Small Block V8 steel line kit	[1073.]	<b>960.80*</b>
<b>22-346LS</b>	56-7 Small Block V8 stainless line kit	[1108.]	<b>991.38*</b>
<b>22-346A</b>	56-7 Big Block V8 steel line kit	[1062.]	<b>950.60*</b>
<b>22-346AS</b>	56-7 Big Block V8 stainless line kit	[1102.]	<b>985.42*</b>



**STOCK SPINDLE 'O' OFFSET POWER Front Disc Brake COMPLETE Kits**

Engineered Components wheel kits with level mount 8" DD booster, 'vette dual master cyl., line kit, prop. Valve & bracket to complete conversion

- 22-EC708-1L 11" Rotors, steel lines for stock spindles 55 **Call**
- 22-EC708-2L 11" Rotors, steel lines for stock spindles 56-7 **Call**
- 22-EC70813-1L 13" Rotors, steel lines for stock spindles 55 **Call**
- 22-EC70813-2L 13" Rotors, steel lines for stock spindles 56-7 **Call**



**WW140-11389**

**Wilwood REAR Disc Brake Kits**

Wilwood Dynapro Low Profile for New Style Ford 3.150" axle tube flange with 2.5" offset. Iron 11" plain face rotor, metallic pads, Black 4 piston calipers. Rotors have both 5 x 4.5 & 5 x 4.75 bolt pattern. Separate internal shoe E brake.

**Wilwood REAR Disc Brake Kits**

4 piston 11 or 12.19 inch rotors .30 offset less than 5/16", Black or Red Calipers, Plain or Drilled & Slotted Rotors. All have Shoe Type E brake. Order flex hoses or sets separately. D154 calipers

- WW140-7141 10/12 bolt 12.19" plain rotor Black 4 piston caliper 2.81 offset **Call**
- WW140-7149 10/12 bolt 12.19" plain rotor Black 4 piston caliper 2.75 offset **Call**
- WW140-7578 10/12 bolt 12.19" plain rotor Black 4 piston caliper 2.81 offset Special 3.15" dia bearing **Call**
- WW140-11405 55-7 stock rear 11" plain rotor Black 4 piston **Call**
- WW140-11348 55-7 stock rear 12.19" plain rotor Black 4 piston **Call**

Grp 23

**Grommets / Cushions / Seals**

MOST ITEMS IN THIS GROUP MADE IN USA UNLESS OTHERWISE SPECIFIED

**Rubber Bumper & Cushion Sets**

Includes hood to fender cushions, hood bumpers, door bumpers, trunk lid or tailgate bumpers. For individual pieces see other listings in this group.

**2 Dr Hardtop & Convertible**

- 23-224 55 16 pcs. **17.50**
- 23-225 56 12 pcs. **14.90**
- 23-226 57 10 pcs. **12.90**

**2 Door Sedan**

- 23-227 55 20 pcs. **23.30**
- 23-228 56 20 pcs. **20.70**
- 23-229 57 14 pcs. **18.70**

**Nomad**

- 23-230 55 16 pcs. **26.10**
- 23-231 56 12 pcs. **23.50**
- 23-232 57 10 pcs. **21.50**

**4 Door Sedan**

- 23-233 55 30 pcs. **30.90**
- 23-431 56 26 pcs. **35.30**
- 23-235 57 24 pcs. **33.30**

**4 Door Wagon**

- 23-236 55 28 pcs. **38.10**
- 23-237 56 24 pcs. **35.50**
- 23-238 57 22 pcs. **33.50**

**4 Door Hardtop**

- 23-309A 56 20 pcs. **20.90**
- 23-309B 57 18 pcs. **22.10**

**Sedan Delivery**

- 23-314 55 20 pcs. **23.00**
- 23-315 56 16 pcs. **20.40**
- 23-316 57 14 pcs. **18.40**

**2 Door Wagon**

- 23-437 55 exc Nmd & Sdn/Del. **30.50**
- 23-438 56 exc. Nmd & Sdn/Del. **24.90**
- 23-439 57 exc. Nmd & Sdn./Del. **22.90**

**Miscellaneous EXTERIOR**

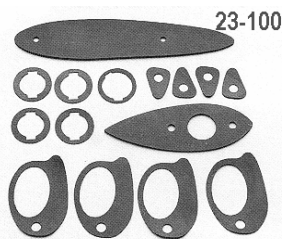

**23-100**

**Exterior Paint Gasket Set**

Includes door handles, locks, mirror & antenna base

- 23-100 2 doors, Set **11.75 R**
- 23-101 4 doors Set **13.90 R**

- 23-136 TAILGATE HANDLE GASKET, Wagon & Delivery Ea. **1.50 R**
- 23-142 LOCK GASKET, Door & Trunk, Ea. N/A Use 23-100 or 101
- 23-104 ANTENNA DONUT SEAL & BASE GASKET, Pr. **3.50 R**
- 23-104A ANTENNA BASE GASKET, Ea. **1.50 R**
- 23-105 Rear ANTENNA BASE GASKET, 57, Ea. **2.25 R**
- 23-105A Rear ANTENNA BASE GASKET, 57, Ea. w/flange around edge **5.00 R**
- 23-144 Outside MIRROR GASKET **2.00 R**

**FRONT END**

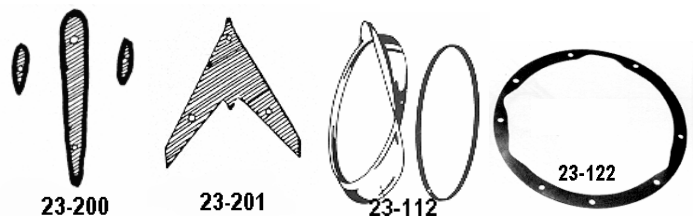

**23-200**

**23-201**

**23-112**

**23-122**

- 23-200 55 Hood Bird GASKET **5.00 RP**
- 23-201 56 Hood Bird GASKET **5.00 RP**
- 23-112 55-6, Headlight Bezel Seals, Pr. **12.90 R**
- 23-113 57 Headlight Bezel, Pr. [also 56 Taillight Bezel] **9.90 R**
- 23-122 Headlight BUCKET to Fender Seal Pr. **8.00 R**
- 23-122D Headlight BUCKET to Fender Seal Pr. Danchuk **11.00 R**

- 23-160** PARK LIGHT HOUSING SEALS, to Body, 55-6, Pr. **7.50 R**
- 23-123** SPLASH PAN SEALS, 57 Rectangular, fit on front splash pan near ends of grill, Pr. **9.50 R**
- 23-123A** SPLASH PAN ANTI-RATTLE SEAL, 57 front to bumper bracket, Set of 4 **4.00 R**
- 23-123B** MOLDED ANTI-RATTLE SEALS, 57 front splash pan to bumper bracket, w/23-123A & mount brackets Set **28.00 R**



23-111

**23-111 Bumper Bullets**, 57, finest quality available, accessory for front bumper, Pr. **45.00 R**

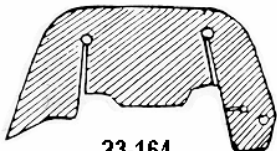

23-164

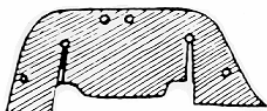

23-166

**'A' ARM DUST SEALS**

- 23-164** 55-56, Pr. **12.90 R**
- 23-166** 57, Pr. (Cork type composite as original) **11.00 R**

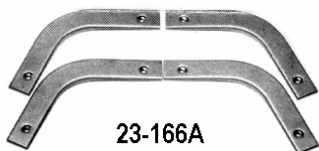

23-166A

**23-166A1 'A' Arm Dust Seal BRACKETS**, 57 arm seals to inner fenders, Set/4 USA **25.00 R**

- 23-166A** 'A' Arm Dust Seal BRACKETS, 57 arm seals to inner fenders, Set/4 with fasteners **19.95 R**
- 23-165A** 'A' Arm DUST SEAL BRACKETS, 56 'A' arm seals to inner fenders w/staples, Pr. **15.00 R**



23-127 23-128

**Hood to Fender Cushions**  
Side of fender at hoodline

- 23-127** 55 Set/6 **6.60 R**
- 23-127D** 55 Set/6 Danchuk **11.25 R**
- 23-128** 56-7 Pr. **4.00 R**
- 23-128D** 55-7 Pr Danchuk **9.00 R**



23-168

**23-168 HOOD BUMPER**, round cushion for hood adjusters 4 req. 55-6 on grill & hood corners at cowl, 2 req. on 57, Ea. **1.00 R**

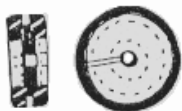

23-167

**23-167 HORN & HEADLIGHT WIRE GROMMET**,

Rad. Support & Inner Fender 55-6, Set of 6 **6.95 R**

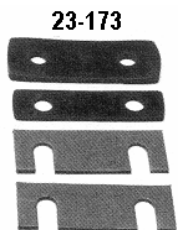

23-173

**RADIATOR SUPPORT SHIMS**

between support & frame,

- 23-173** T&N Set **15.00 R**
- 23-173D** Danchuk Set **13.75 R**

METAL SHIMS SEE Rad Support section page 77



- 23-223A ELECTROVAC GROMMET** Fuel Injected cars, in rad. support where hose passes through from pump **6.80 R**

**Headlight Bucket GROMMET**  
for Harness

- 23-223A** 57, Pr. **6.00 R**
- 23-223** 55-6, Ea. **2.00 R**

**Hood Anti-Squeak Kits**

- 23-137** 55-6 Strips between hood skin & inner braces **9.90 R**
- 23-138** 57 Strips between hood skin & inner braces **12.50 R**



23-155 / 156

**Inner Fender Vertical Seals**

For inner fender edge to seal against front fender in wheel well,

- 23-155** 55-6, Pr. [Rte 66] **19.90 R**
- 23-155D** 55-6, Pr. [Danchuk] **24.00 R**
- 23-156** 57, Pr. [Rte 66] **20.90 R**
- 23-156D** 57, Pr. [Danchuk] **24.00 R**

**Front Fender Anti-Squeak Kit**

Complete set of seals for bolting together inner fender & fender & splashpan

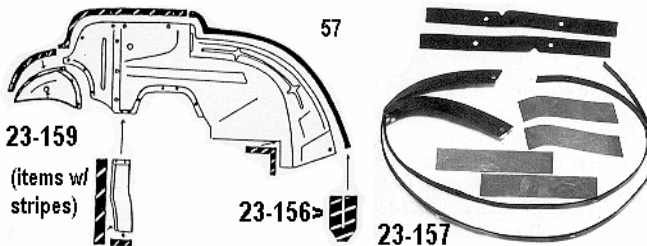

23-159

(items w/ stripes)

23-156

23-157

- 23-157** 55 **19.90 R**
- 23-158** 56 [Danchuk] **25.00 R**
- 23-159** 57 [Danchuk] **22.00 R**
- 23-158T** 56 **25.00 R**
- 23-159T** 57 **19.00 R**

**FIREWALL & COWL**

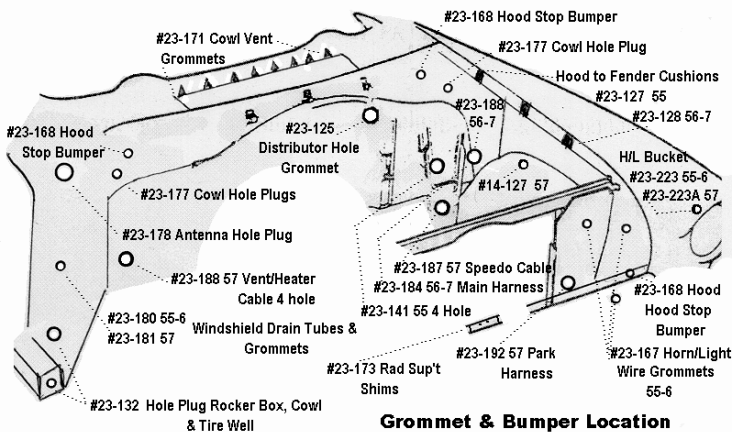

**Grommet & Bumper Location**

**COWL SEAL**

Top of Cowl to Hood

- 23-114** 55-6 **16.00 R**
- 23-114D** 55-6 Danchuk **17.50 R**
- 23-115** 57 **16.00 R**
- 23-115D** 57 Danchuk **17.00 R**
- 20-180** Cowl Seal CLIPS, 55-6 Set USA **8.00 R**
- 20-157** Cowl Seal CLIPS, & Screws, 57, Set USA **6.00 R**

**FIREWALL PLUG & GROMMET SET**

- 23-444 **55** Includes 23-125, 141, 180, 2/ 177, 2 / 132 **32.85 R**
- 23-445 **56** Includes 23-125, 141, 181, 184, 2 / 132, 2/ 177 **37.35 R**
- 23-446 **57** Includes 23-125, 184, 187, 181, 2/ 188, 2/ 177, 2/ 132 **45.25 R**

**GROMMETS**



- 23-125 Firewall DISTRIBUTOR HOLE, Next to Wiper Motor, can also be used as Rp. 57 Headlight Bucket Grommet & Wagon Taillamp Harness Hole in rear cargo floor left side. Ea. **3.90 R**
- 23-141 FIREWALL 4 HOLE, drivers side of firewall, 55 **3.95 R**

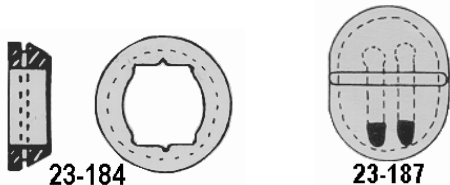

- 23-184 Firewall Main HARNESS PLUG in Firewall, 56-7 **4.50 R**
- 23-187 Firewall SPEEDO CABLE, 57, Oval Shaped **3.95 R**

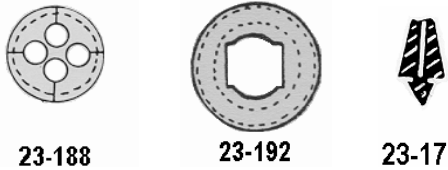

- 23-188 Firewall 4 HOLE, Heater Cable 57 (2 req.), 56 Speedometer Cable, Ea. **3.95 R**
- 23-192 Park Light HARNESS PLUG in Rad. Support, 57 **3.75 R**
- 23-171A Fresh Air VENT DOOR SEALS, 55-6 set **15.00 R**
- 15-144 Clutch Pedal PUSH ROD FELT at Firewall **8.00 R**
- 23-171 COWL VENT SET / 8, supports back of grate, 55-6 **N/A**
- 23-171-D COWL VENT SET / 8, back of grate, 55-6 Danchuk **8.00 R**

**DOOR AREA**



**DOOR BUMPERS**

- 23-133 Oblong, 2 hole **.95 R**
- 23-134 Round, 1 hole, 3/8" tall **.90 R**
- 23-135 Round, 4 Dr rear door, 1 hole, 1/2" tall **1.60 R**



- 23-199 Round, 1 hole w/screw, all Sedan/Wgn upper door front corner **2.20 R**
- 23-202 Rectangular, 4 dr Sedan, mounts on door **1.50 R**
- 23-203 Rectangular, 56-7 4 dr HT mounts on door **1.50 R**
- 20-198 Door Bottom Drain Seal CLIP plastic RP, Ea. **.50 RP**

**DOOR GLASS BOTTOM STOP in Bottom Center of Door**

- 23-197 All Sedans/Wagons, Ea. **2.00 R**
- 18-162 HT, CV, Nomad Ea. **N/A**
- 18-162D HT, CV, Nomad Ea. [Danchuk] **5.25 R**



- 23-174 Door Access Hole Plugs, Sedan, Pr. **3.50 R**
- 23-183 Door Bottom Drain Seals, Set for 2 doors **9.75 R**
- 23-183D Door Bottom Drain Seals, w/clips Set for 2 doors **14.00 R**
- 23-436 Door Access Plug, 56-7 4 Dr. HT Rr. Door, Pr. **5.50 R**
- 23-143 Door JAMB SWITCH GASKET, 55-6, Ea. **1.85 R**
- 23-143A Door JAMB SWITCH GASKETS, 57 Pr. **1.95 R**

**HOLE PLUGS**

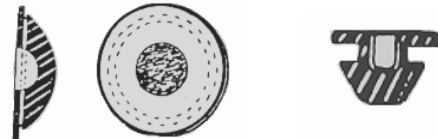

- 23-132 Spare TIRE WELL (2 Req.) & ROCKER PANEL End Plug (4 Req.), Each **1.50 R**
- 23-132D Spare TIRE WELL Danchuk Each **4.50 R**
- 23-177 Top of COWL, (1/2" hole 2 Req.), Each **1.65 R**
- 23-178 Front fender ANTENNA HOLE, in Cowl (1 1/4" hole) Each **5.00 R**
- TRUNK ACCESS PLUG, Inside, (4 req.) on upper side walls, 23-179 Each **4.00 R** 23-179DS Set of 4 **16.50**



- 23-189 INNER ROCKER DRAIN Plug w/square flap, Pr. **4.80 R**
- 23-189D INNER ROCKER DRAIN Plug w/square flap, Pr. Danchuk version of 23-189 **9.90 R**
- 23-193 DOME LIGHT WIRE Rubber Plug, (1 1/2" hole) all Hardtops **5.00 R**
- 23-196 Body Mount BOLT ACCESS PLUG, (in rear of trunk behind tailpan) also used in floor pan (1 7/16" hole size) Ea. **3.00 R**
- 23-204 FLOORPAN & Misc. 3/4" Hole Plug, Ea. **2.00 R**
- 23-204A HOLE PLUG Floor Pan & Misc. fits 9/16 hole **1.70 R**

**DRAIN TUBES and GROMMETS**



- 23-181 55 **12.70 R**
- 23-181 56-7 **12.70 R**
- 23-180D 55 [Danchuk] **17.50 R**
- 23-181D 56-7[Danchuk] **17.50 R**
- Windshield Set**
- 23-208 55-7 **13.50 R**
- 23-207 56-7 4 Dr HT **13.50 R**
- 23-208D 55-7 Danchuk **17.50 R**
- 23-207D 56-7 4 Dr HT Danchuk **17.50 R**
- Rear Glass Set**

## REAR OF CAR

### TRUNK LID

- 23-107 License Plate SEALS, to trunk lid, Pr. **1.50 R**
- 23-129 License Plate BUMPER, Ea. **.70 R**

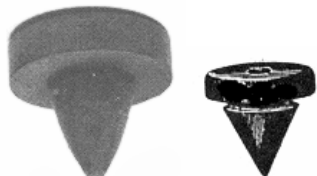

**23-169**      **23-185**

- 23-169 Trunk Lid LOWER BUMPER in tailpan 2 req., Ea. **1.90 R**
- 23-185 Trunk Lid UPPER BUMPER, bottom of lid 2 req., Ea. **.80 R**

- 23-213 Continental Kit Bumper, that screws to tailpan **19.90 R**
- 23-215 Back-up Lamp Seal, to Bumper End, 57, Pr. **2.00 R**

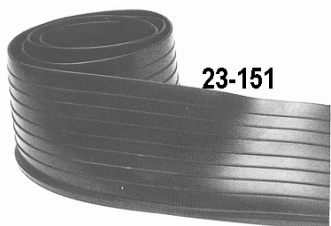

**23-151**

### Rear Bumper to Body Seal

- 23-153 55 **15.50 R**
- 23-153D 55 DANCHUK **27.95 R**
- 23-152 56 **15.90 R**
- 23-152D 56 DANCHUK **19.90 R**
- 23-151 57 **18.95 R**
- 23-151D 57 DANCHUK **23.00 R**

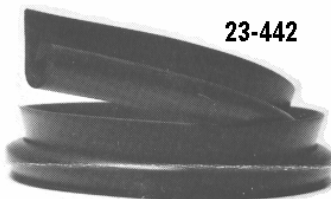

**23-442**

- 23-442 55-8 Continental Kit to body Pr. Use this in addition to the standard seal for your year shown above **17.50 R**

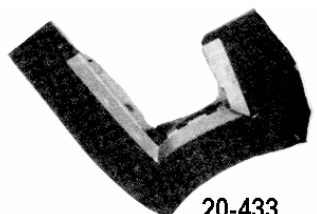

**20-433**

### Taillight Housing Seals

- 20-433 57 w/Brackets attached, Pr. **23.00 R**

- 23-110 57 DUST SEAL, flat 'U' shaped seal that fits on bottom of taillight housings, Pr. **13.80 R**
- 23-147 57 HOUSING SEALS, to Body, 57, slide in back of each housing, Set for both housing, **6.50 R**
- 23-109 56 DUST SEAL, fits on bottom of quarter panel below taillights, Pr. **11.00 R**
- 23-113 56 TAILLIGHT BEZEL, Pr. [also 57 Headlight Bezel] **9.90 R**
- 23-149 56 INNER SEALS, Taillight to Taillight Rim, Set **7.00 R**
- 23-148 55 HOUSING SEAL to Body, Pr. **6.50 R**



**23-234A**

### LICENSE LIGHT WIRE GROMMET

- 23-234 55-6, Also tank sender wire in trunk floor. Ea. **1.80**
- 23-234B 56 Pr. in bumper **4.80**
- 23-234A 57, Pr. **4.50**

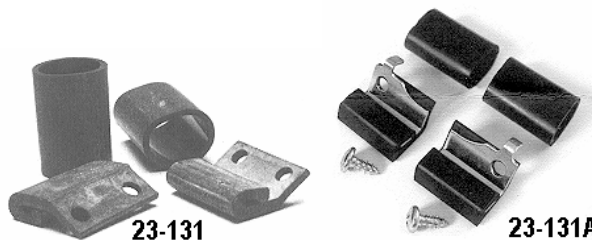

**23-131**

**23-131A**

### GAS DOOR BUMPERS

- 23-130 49-55, Pr. w/screws **3.00**
- 23-130D 49-55, Pr. w/screws Danchuk **5.50**
- 23-131 57, Set **5.50**
- 23-131A 57 w/Brackets & screws **8.00**

### WAGON TAILGATE



**23-172**

- 23-172 Nomad TAILGATE BUMPER, Set of 4 **5.50 R**



**23-172L**

### Tailgate Bumper

'L' BRACKET Wagons & Sedan Delivery on either side of gate for 2 hole bumper 23-172L [2 per 'Gate], Each **9.75 R**

- 23-172LS with screws [2 per 'Gate], Each **11.50 R**



**23-214**

- 23-214 Wagon LIFTGATE BUMPER, 3" long, Ea. **4.50 R**



**23-306**

- 23-306 Nomad LIFTGATE BUMPER 2" long 2 tabs, Pr. **8.90 R**

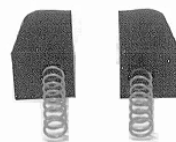

**23-214A**



**23-214B**

- 23-214A Tailgate Nylon Center GUIDE BUMPERS w/springs Pr, Wagon /Nomad **8.90 R**
- 23-214B Tailgate Nylon Bumper SPRINGS only, Pr stainless **2.50 R**

### QUARTER PANEL AREA



**23-145**

### Gas Tank FILLER NECK 'O' RINGS

- 23-145 Stock necks w/2" O ring groove **3.50 R**
- 23-145A Oversize for necks if 23-145 is too small **6.00 R**
- 23-145B Undersize for filler necks when 23-145 is too big some repro necks w/2-1/16" O ring groove **3.50 R**



**23-304**

**23-304** Gas Tank FILLER NECK GROMMET, to Body, 56 Ea. **18.40R**

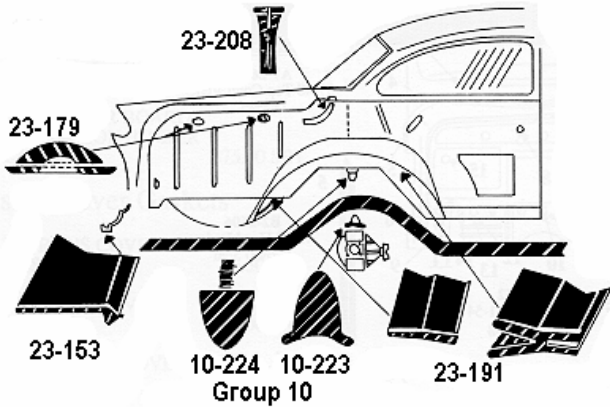

**23-191** WHEEL HOUSE SEAL, Edge of rear well to Quarter, both sides [T&N] **28.00R**  
**23-191D** WHEEL HOUSE SEAL, Edge of rear well to Quarter, both sides [Danchuk] **28.50R**



**23-191A**

**23-191A** WHEEL HOUSE SEAL, Upper rear well center brace to quarter Pr. **11.00R**

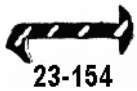

**23-154**

**23-154** FENDER SKIRT SEALS, Pr. **14.00R**

Rear Glass Drain Tubes

**23-207** 56-7 4 Dr Hardtop, Pr. **13.50R**  
**23-207D** 56-7 4 Dr HT, Pr. [Danchuk] **17.50R**  
**23-208** 55-6 & 57 Rp. Sdn **13.50R**  
**23-208D** 55-6 & 57 Rp. Sdn [Danchuk] **17.50R**

**10-223** LOWER AXLE BUMPER, mounts on housing on each end, stops housing from bottoming on frame, Ea. **7.50R**  
**10-223AD** Axle Bumper RETAINERS Pr. **24.90R**

**10-224** PINION BUMPER, mounts on floor pan above 'pumpkin', Ea. ( for bracket see Group 11 ) **14.90R**

**INTERIOR**

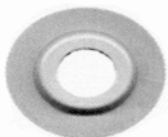

**23-194**

**23-194** Inside Handle Washer to Upholstery, Plastic, Ea. **1.70R**  
**Window Regulator Grommet** to mount to Door, Set/4  
**23-140** T&N **6.95** **23-140D** Danchuk **9.90**

**23-448** TOP CYLINDER GROMMET Convert. Lower In Support Bracket, Pr. **5.50R**  
**23-195** Top MOTOR WIRE GROMMET, Convertible, also early 55 starter harness grommet under battery box **5.00R**  
**23-429** SUNVISOR, 'O' RING, inside ends conv. Pr **2.50R**  
**23-102** Dimmer SWITCH GROMMET, in carpet, Ea. **6.00R**  
**23-106** GAS PEDAL & DIMMER SWITCH GROMMETS, to trim cuts in carpet, Pr. **18.00R**



**23-175F**



**23-176F**



**23-307**

**SEAT BACK STOPS SEAT BRACKETS See GROUP 20 & 26**

**23-175F** 55-6, & some 57s Set / 4 [Oval shape] **10.90RF**  
**23-175D** 55-6, & some 57s Set / 4 [Oval shape] Danchuk **14.90RF**  
**23-176** 57, Set of 4 [Round] Gene Smith NOS **9.95 RF**  
**23-176D** 57, Set of 4 [Round] Danchuk **14.90 RF**  
**23-307** UPPER SEAT STOPS metal 55-6 front seat, Set/4 **14.50R**  
**23-175S** Seat Stop SCREW SET, Upper & Lower 16pc.Set **2.50 RP**



**23-176P**



**23-176R**

**23-176P** SEAT STOP PLATES, 57 for round seat stops Set/3 **24.00R**  
**23-176R** Wagon REAR SEAT STOPS, Set/4 **17.90R**



**23-126**



**23-126A**



**23-198**



**23-443**



**23-206**

**23-126** Glove Box Door BUMPER, (in dash, 2 req.) Ea. **.60R**  
**23-126A** Dash ASHTRAY BUMPER 55-6, Ea. **1.00R**  
**23-126B** Dash ASHTRAY BUMPER 57, Ea. **1.00R**  
**23-198** Glove Box HINGE STOP BUMPER, Ea. **1.50R**  
**23-443** GARNISH MOLDING BUMPER, to Vent Division bar Ea. **1.80R**  
**23-206** Nomad SLIDING GLASS STOPS, Pr. **4.40R**



**23-320**

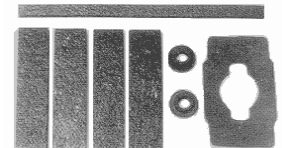

**23-320A**

**GAUGE CLUSTER GASKETS**

**23-320A** 55-6 Set for assembling gauges T&N **10.00R**  
**23-320AD** 55-6 Set for assembling gauges Danchuk version **10.00R**  
**23-320** 57 Set for assembling gauges T&N **9.00R**  
**23-320D** 57 Set for assembling gauges Danchuk version **9.40R**  
**23-190** Radio SPEAKER BOOT, to Dash 55-6, rubber **29.00R**  
**23-186B** Autronic Eye GASKET, Accessory to dash, Ea. **12.00R**

**20-566** Instrument CLUSTER SCREWS, small screws to assemble gauges & support brackets to instrument cluster housing 21 pc set **3.80R**  
**20-566A** Instrument CLUSTER BEZEL SCREWS, 55-6 Set **3.60R**  
**20-580A** DASHBOARD FASTENER KIT, 55-6 All the screws & J nuts to assemble dash trim dash cluster bezels and column to dash. **7.00R**  
**20-566B** Instrument CLUSTER MOUNTING KIT 57 includes upper column area to dash screws **4.40R**  
**19-256B** SPEAKER GRILL STUDS 57 for stock dash grill **9.00 RP**  
**20-004B** DASH END CAP SCREWS, chrome, 57 Pr. **1.00R**